

Features:

- ◆ 1: 1CT Impedance
- ◆ 50Ω Characteristic Impedance
- ◆ Frequency: 0.4 to 500 MHz
- ◆ RF power: 0.50W
- ◆ DC current: 30mA
- ◆ Operating temperature range: -40°C to +85°C
- ◆ Storage temperature range: -55°C to +100°C

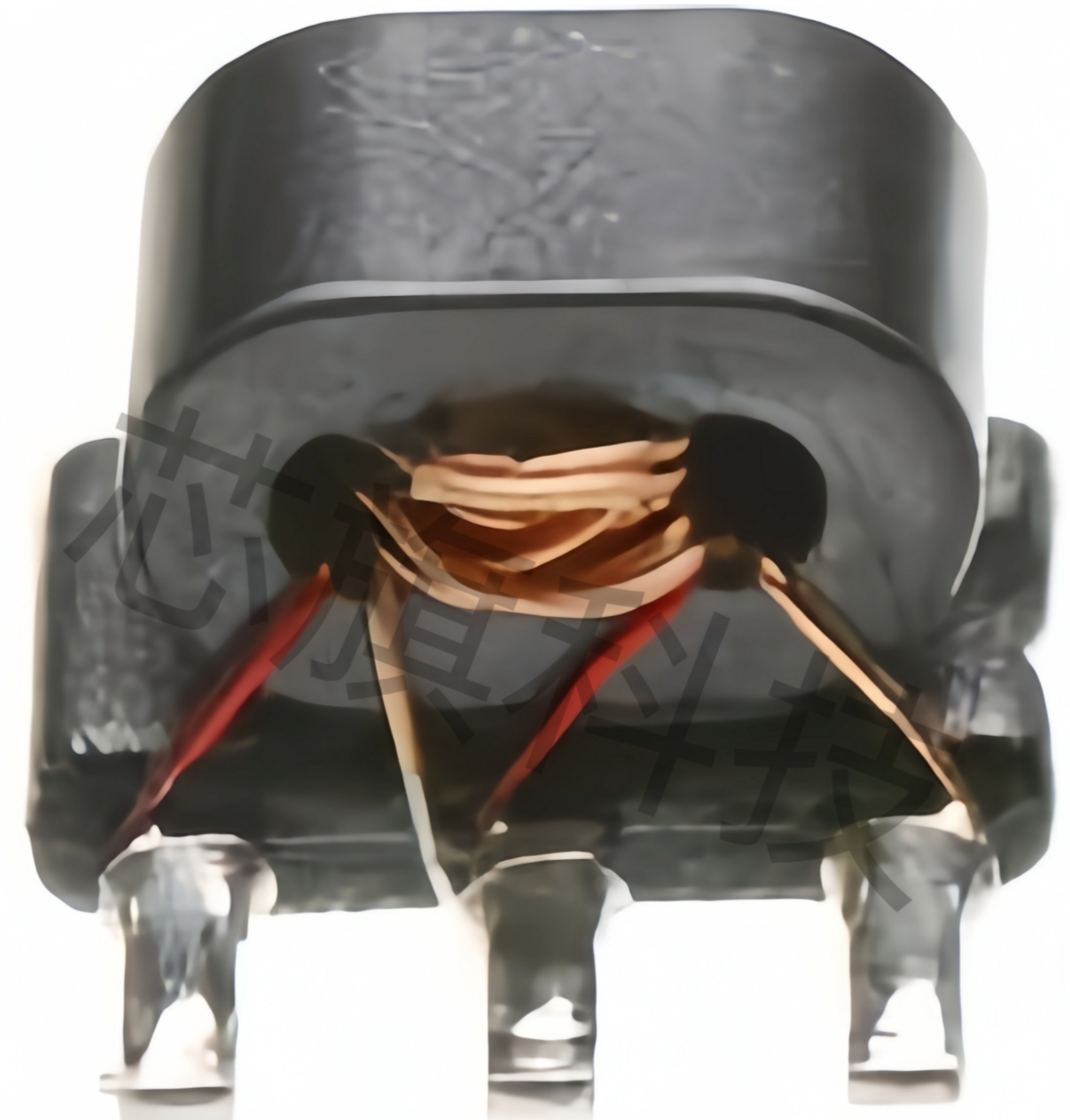

Applications:

- ◆ For broadband and wireless communications
- ◆ For VHF/UHF receivers/transmitters and push-pull amplifiers

Dimension Diagram (Unit:mm) :

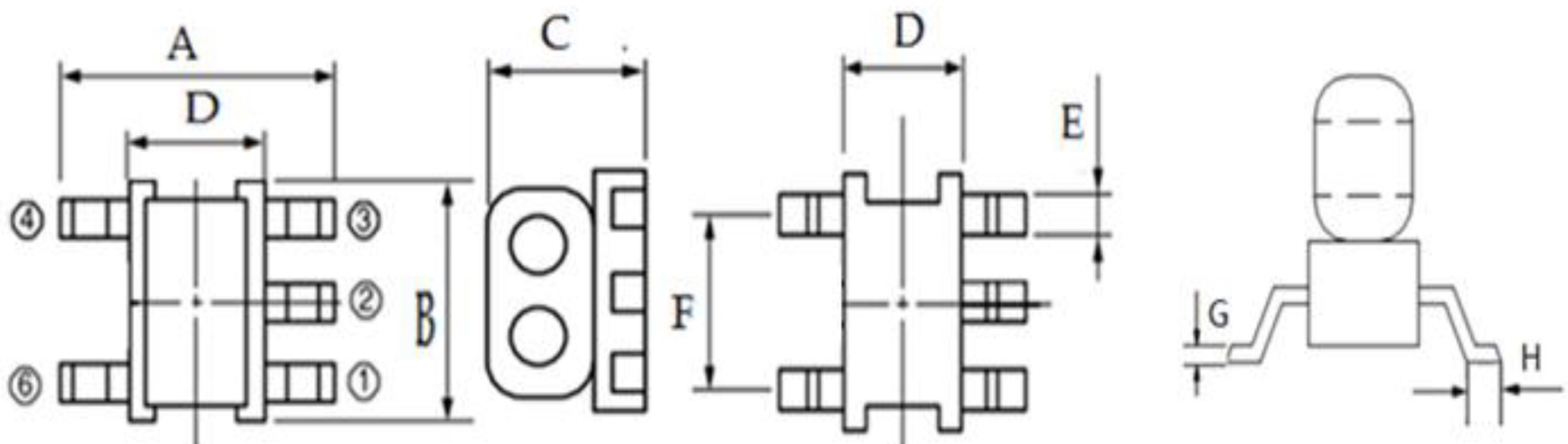

A=4.10±0.20 B=3.80±0.20 C=3.20±0.20 D=2.80±0.20 E=0.55±0.05 F=2.54±0.05 G=0.25±0.05 H=0.60±0.05

Electrical structure:

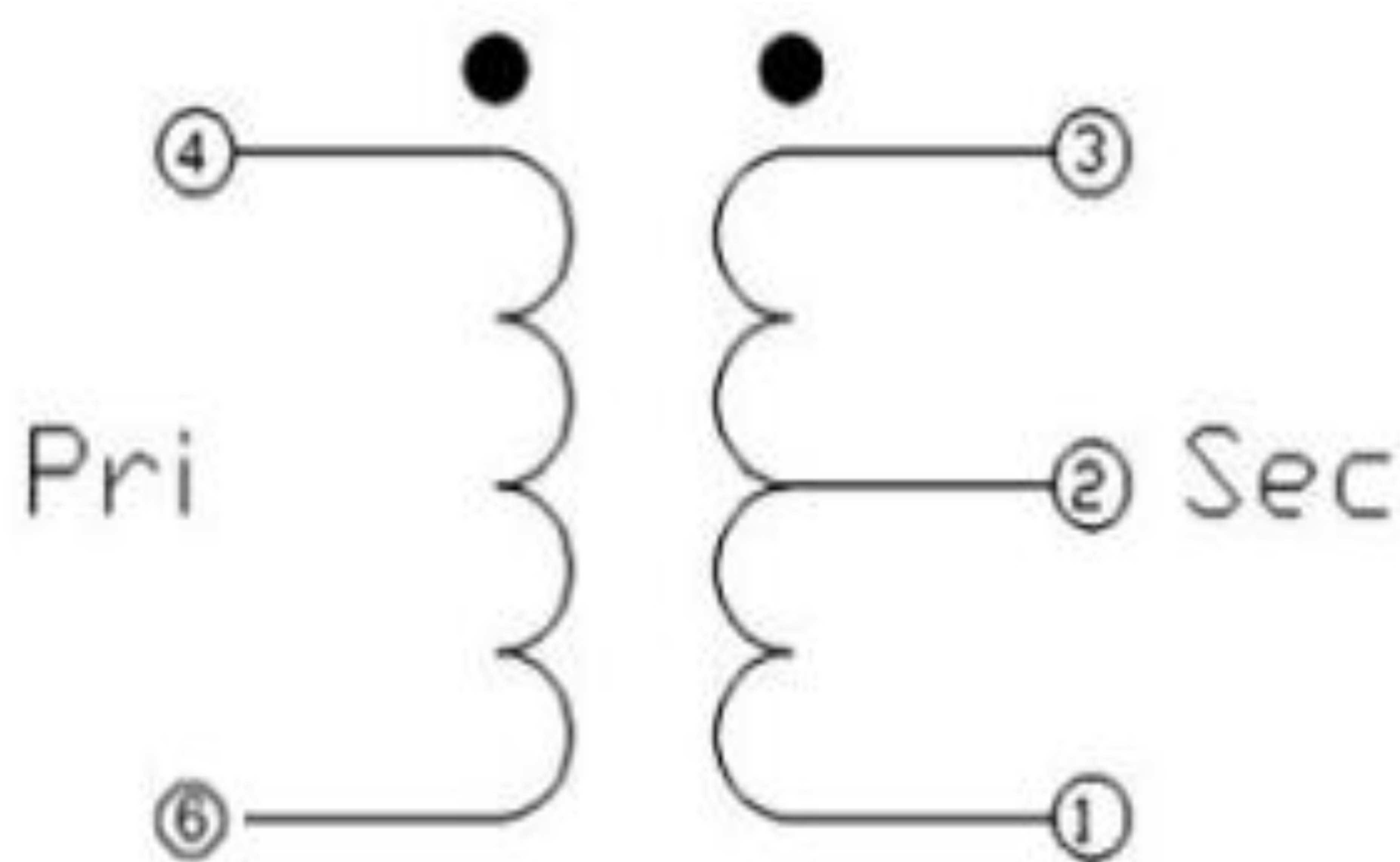

Schematic

Recommended layout:

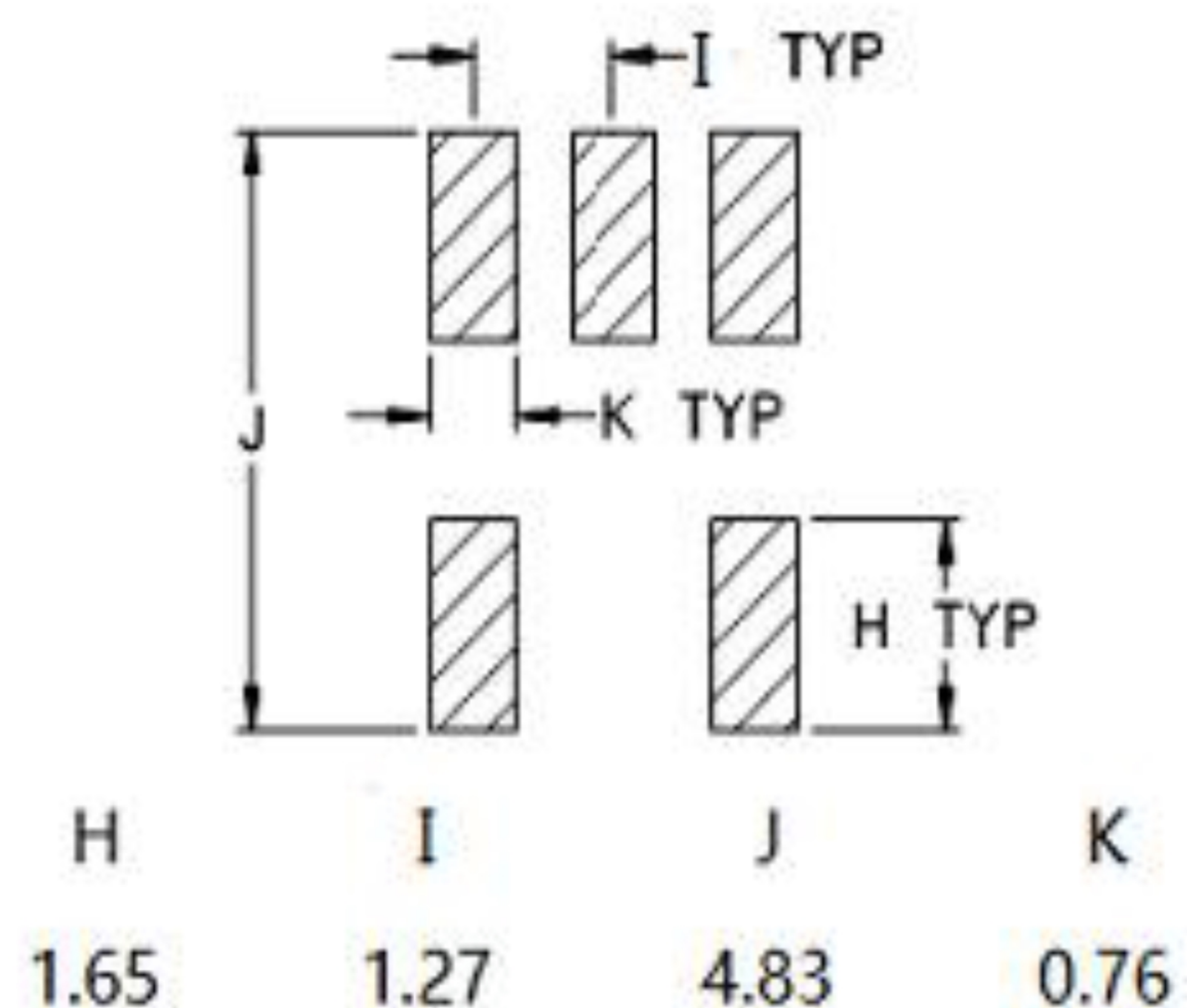

Pin configuration

Pin no.	Function
1	Secondary dot (Output 2)
2	Centre tap (Ground)
3	Secondary (Output 1)
4	Primary ((Input)
6	Primary dot (Ground)

Application circuit :

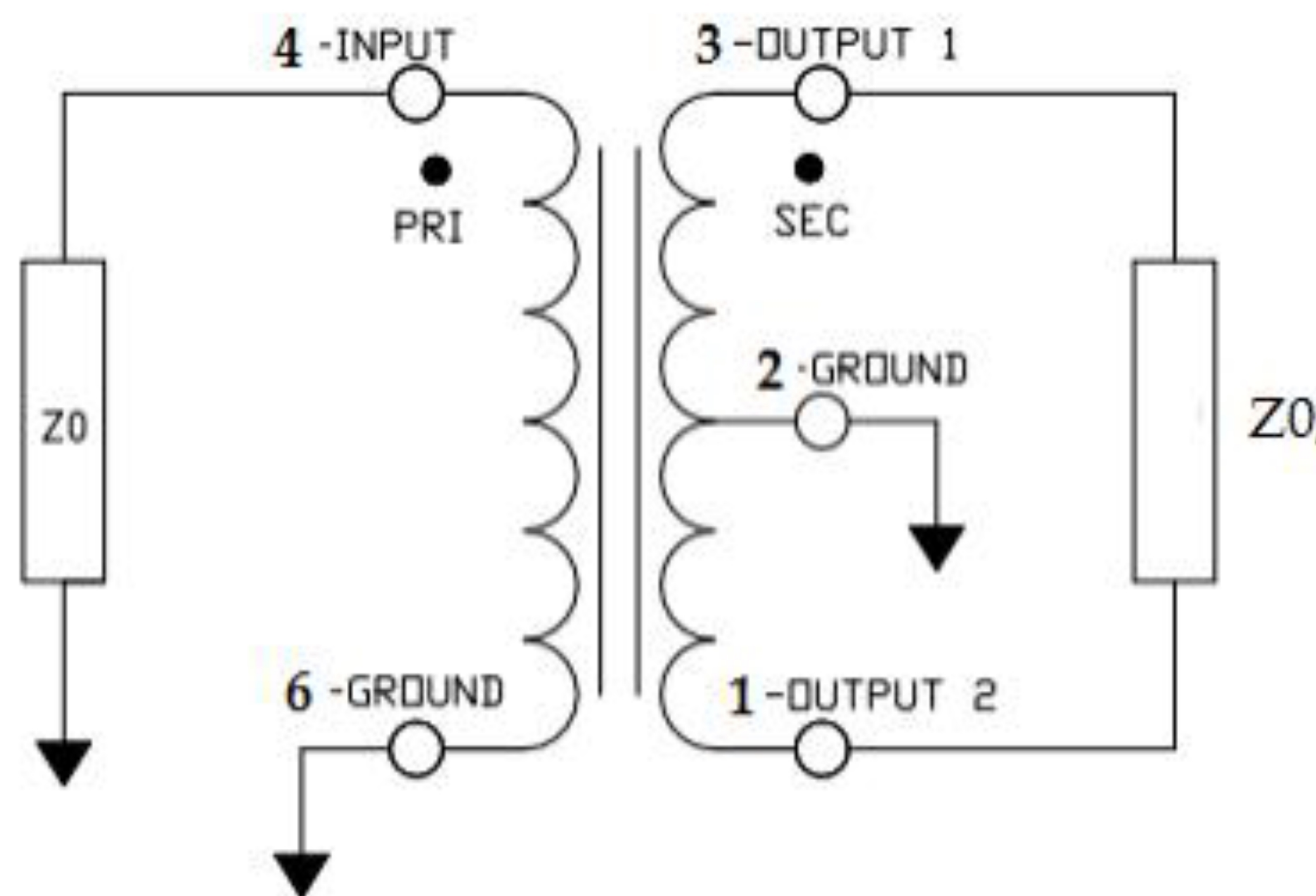

Electrical Specifications: $T_A = 25^\circ\text{C}$ $Z_0 = 50\Omega$,

Parameter	Test Conditions	Units	Min	Typ	Max
Main line Loss(out1)	0.4-500MHz	dB	—	0.8	3.0
Main line Loss(out2)	0.4-500MHz	dB	—	0.7	2.0
Amplitude Balance	0.4-500MHz	dB	—	0.5	± 1.0
Phase Balance	0.4-500MHz	Degrees	—	5.0	± 10.0
Input Return Loss	0.4-500MHz	dB	5.0	15.0	—

Main line Loss(out1)

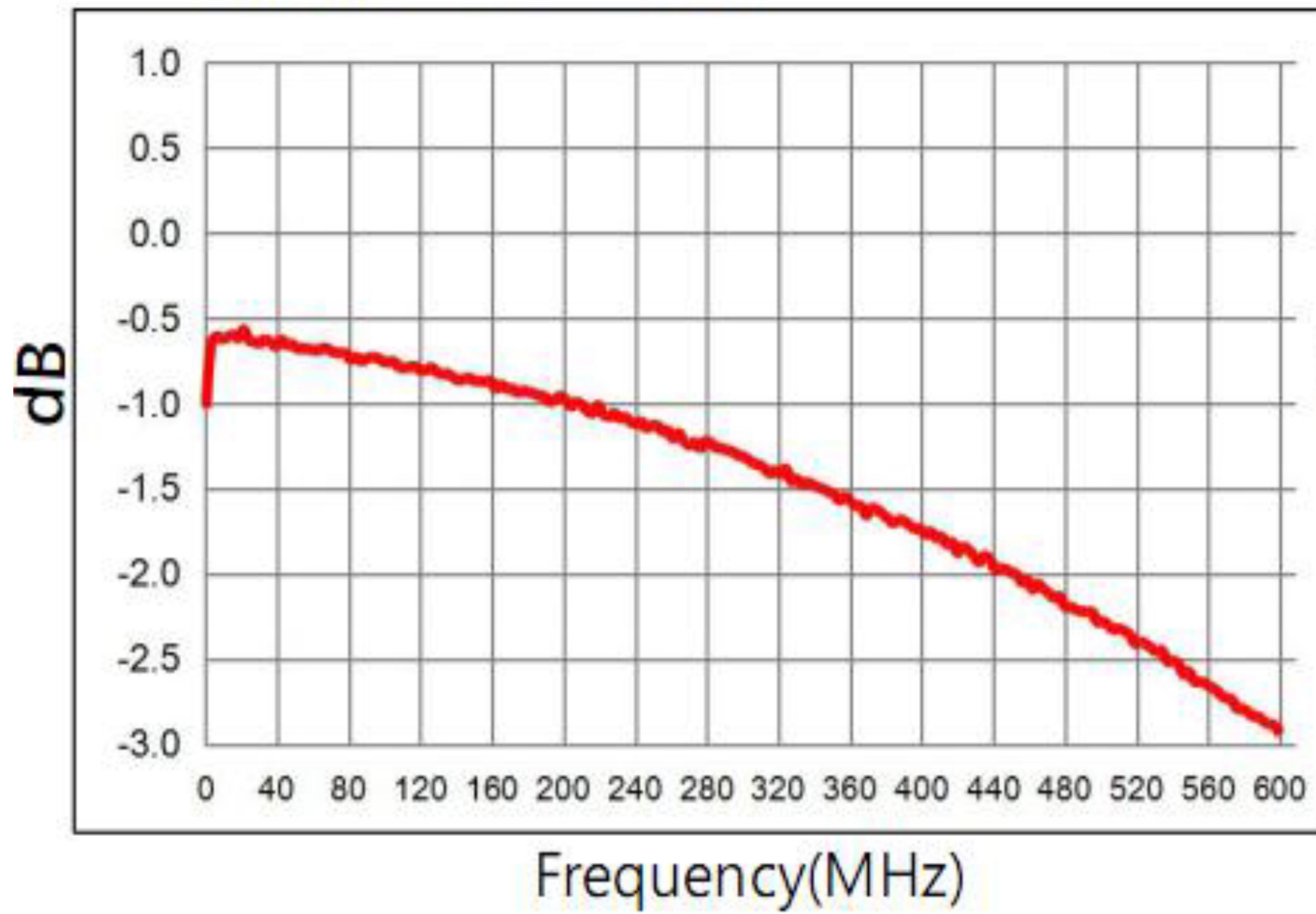

Main line Loss(out2)

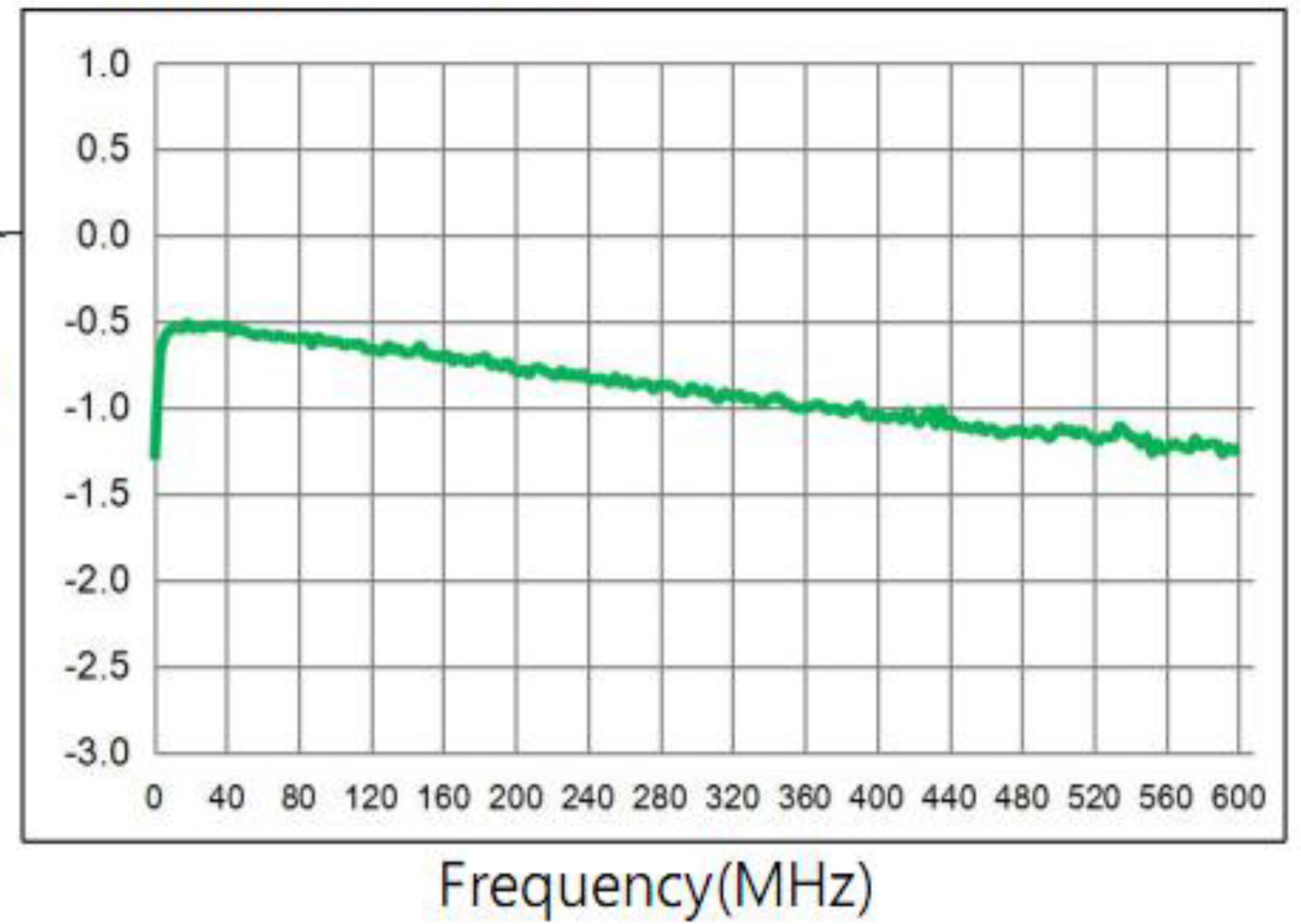

Amplitude Balance

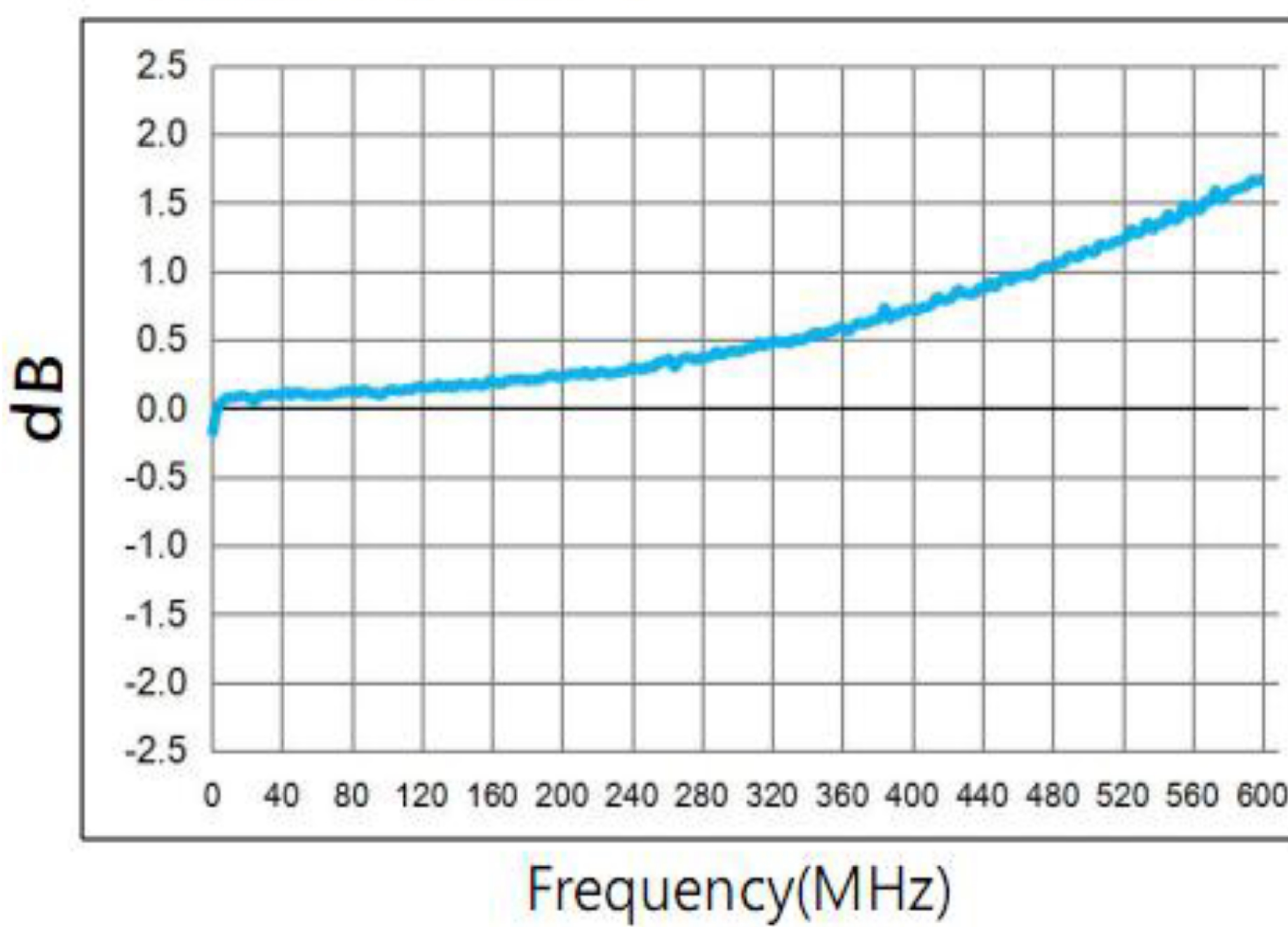

Phase Balance

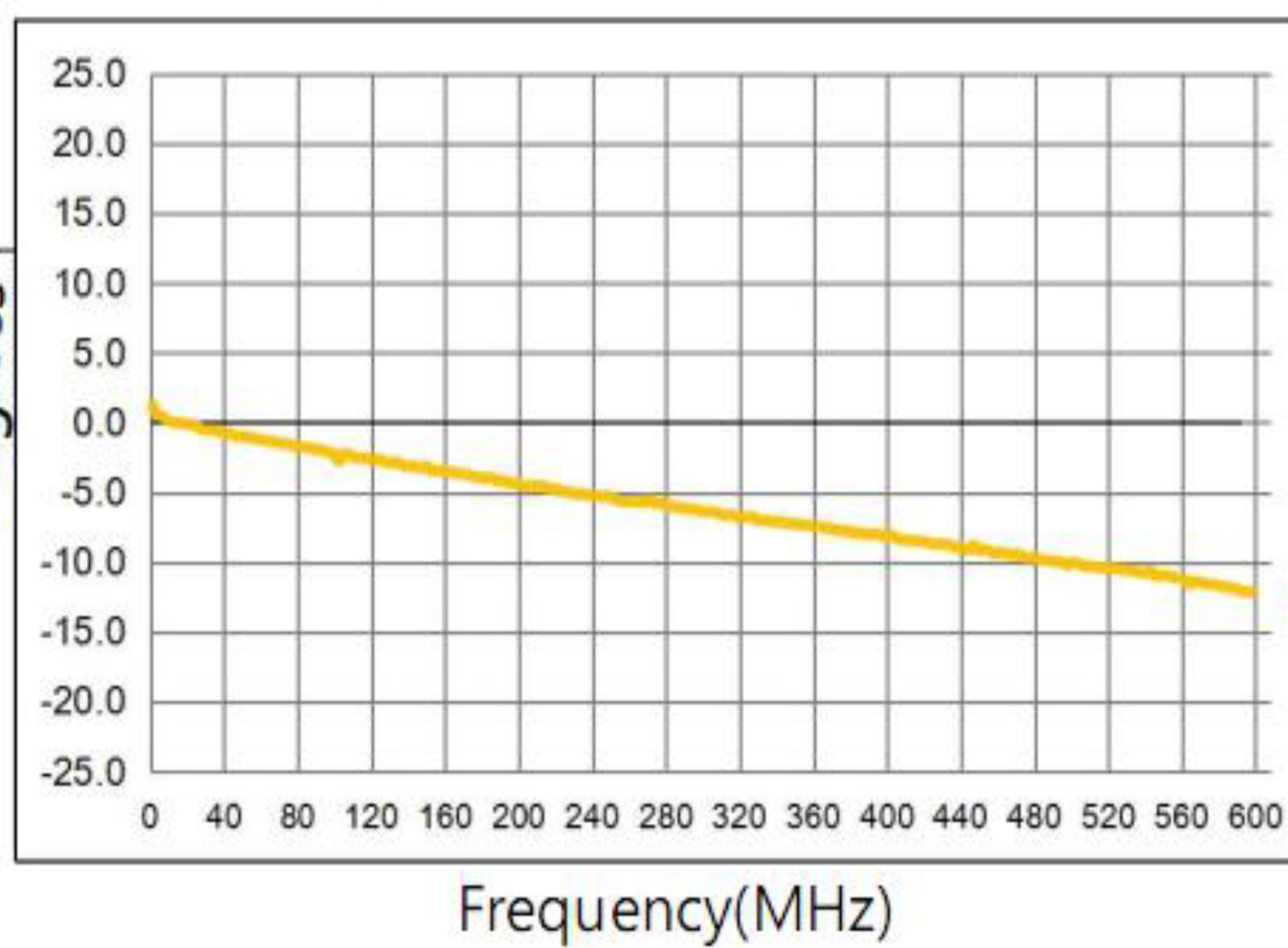

Input Return Loss

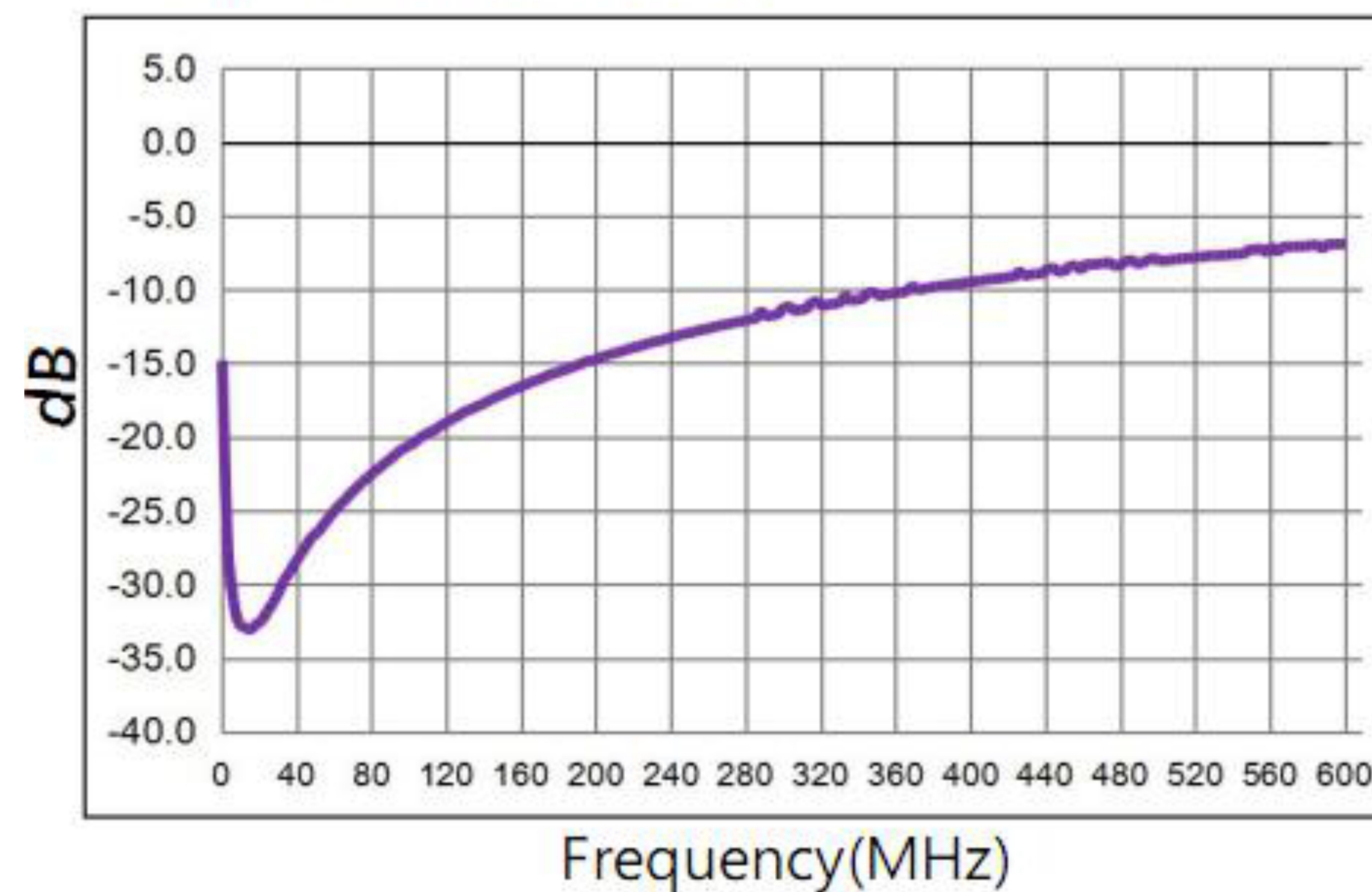

Sdd22

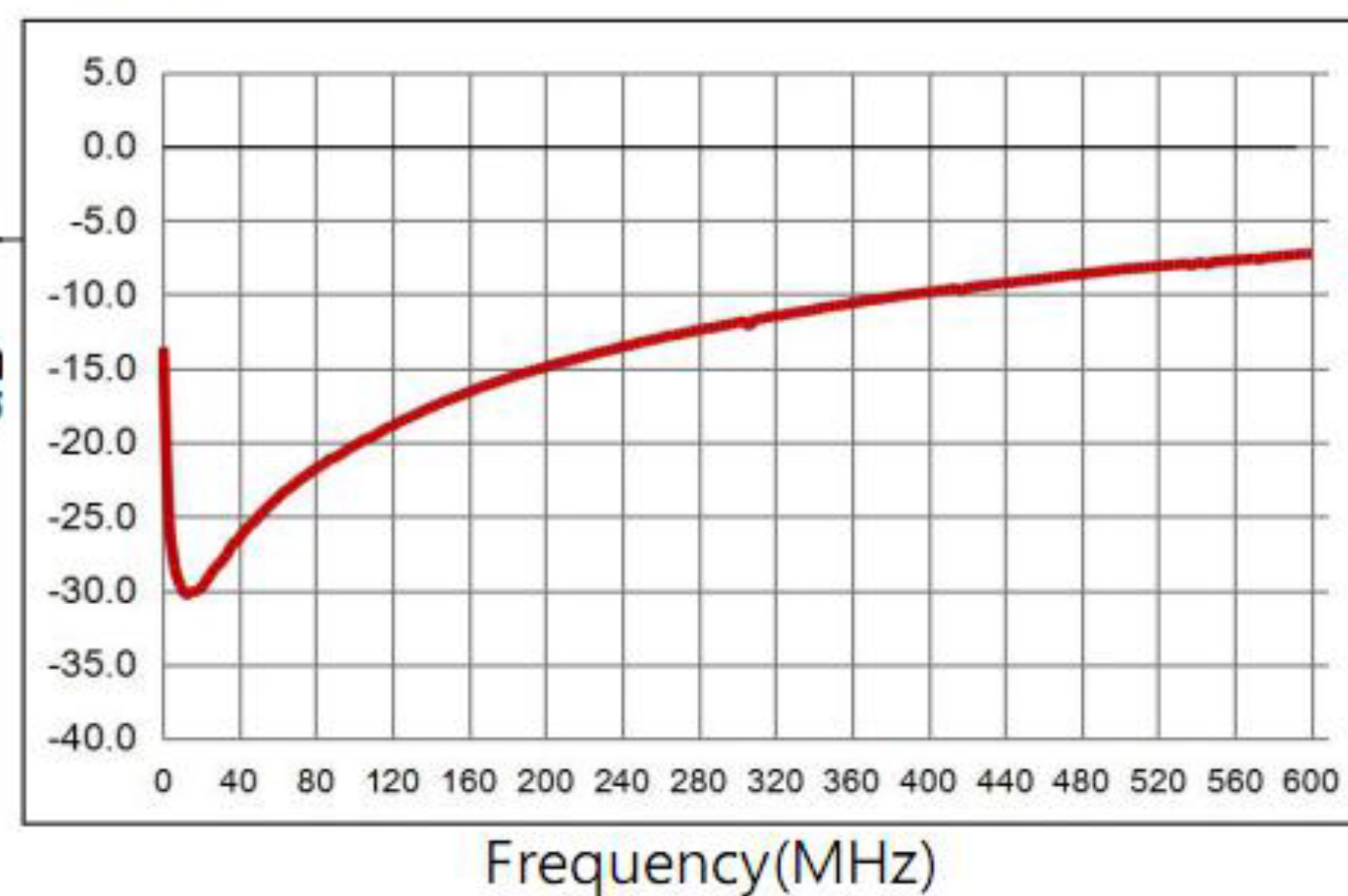

Recommended Soldering Temperature Graph:

建议迴焊条件
The condition of reflow
(Recommendation)

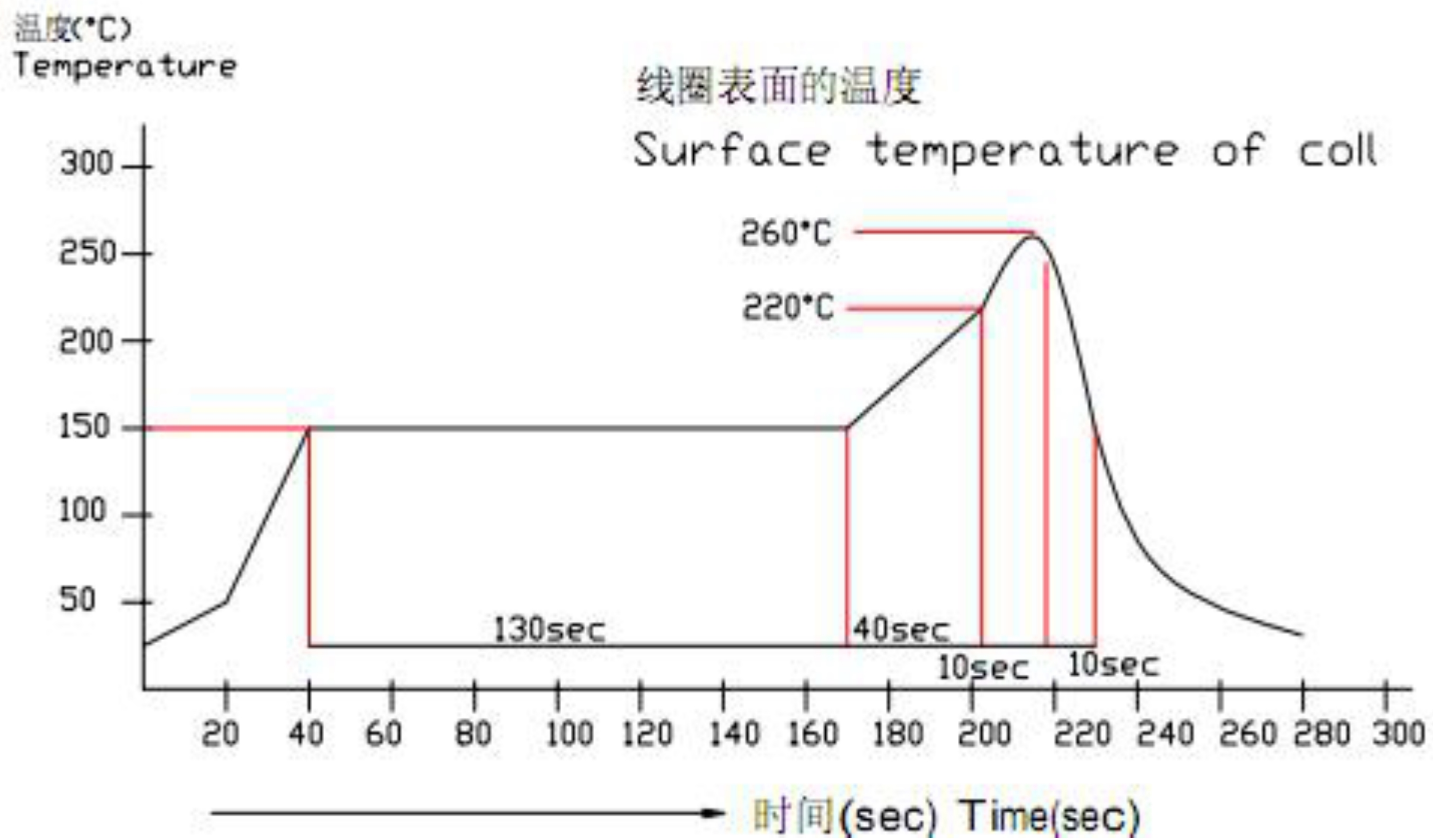

Packging Dimension For Caeier Tape(UNIT:mm):

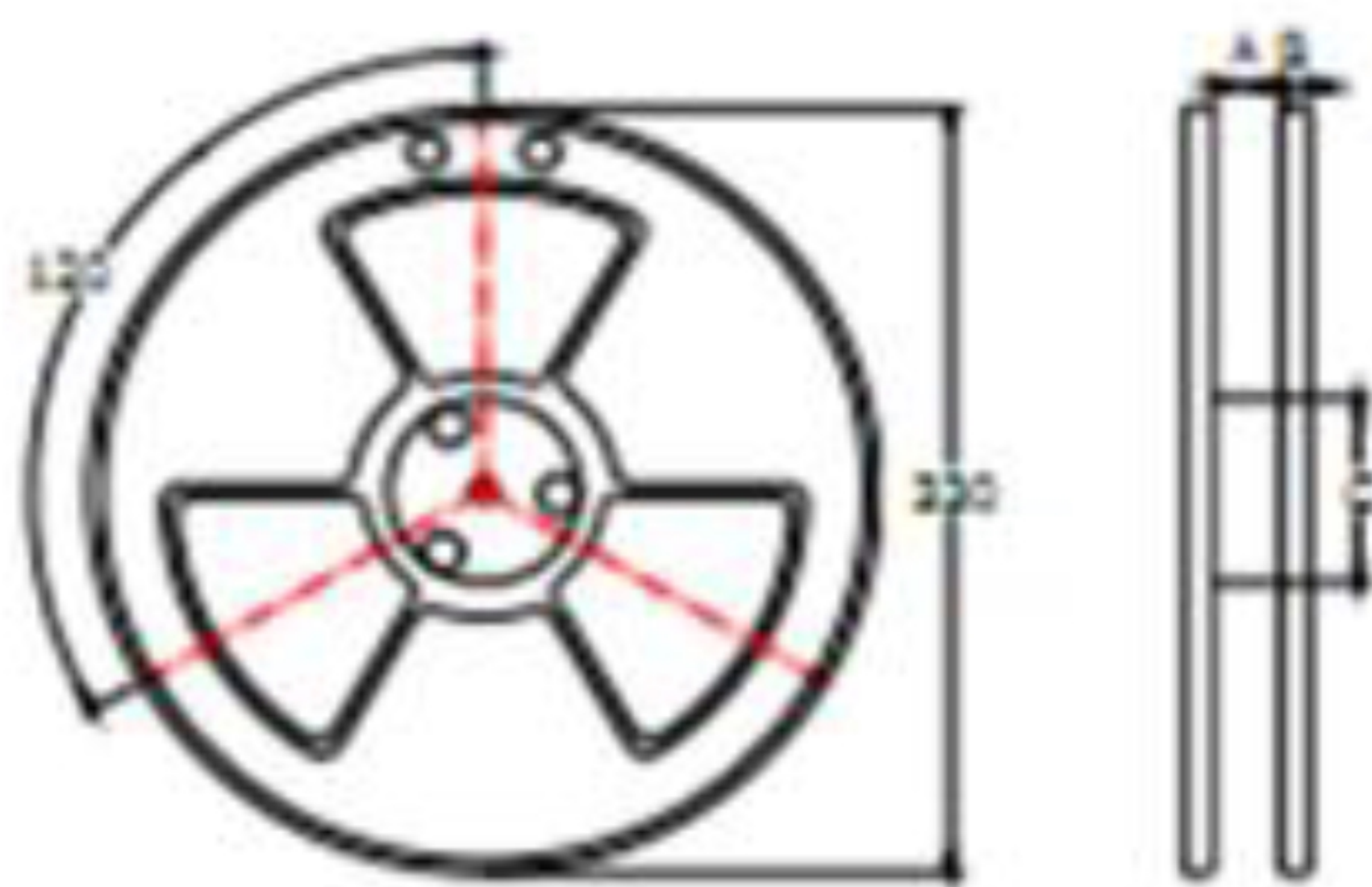
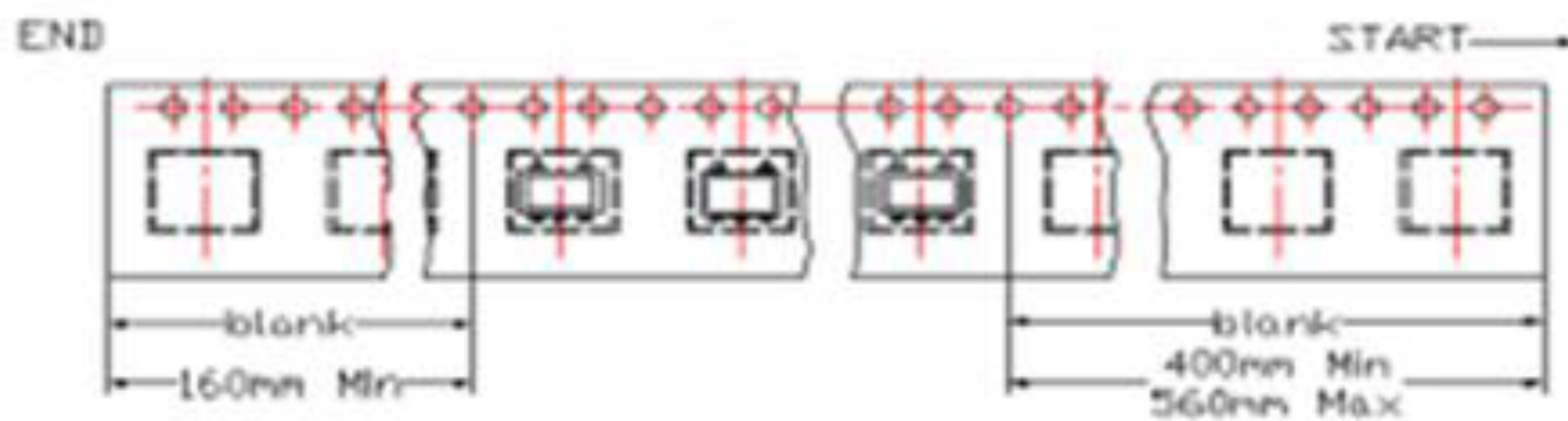

SPEC	8	12	16	24	32	44	56	72
DIM A±0.1	8.5	12.5	16.5	24.5	32.5	44.5	56.5	72.5
DIM B±0.1	2.3	2.3	2.3	2.3	2.3	2.3	2.3	2.3
DIM C±0.1	100	100	100	100	100	100	100	100

QUANTITY
2000PCS/Reel

15 reel/Big carton/60000pcs