

Features:

- ◆ 260°C reflow compatible
- ◆ RoHS Compliant and Pb free
- ◆ Operating temperature range: -20°C to +85°C
- ◆ Storage temperature range: -55°C to +100°C



Applications:

- ◆ For Docsis 3.0 & 3.1 Cable Modem.
- ◆ For Wideband Push-pull Amplifiers.
- ◆ For CATV Amplifiers Module & Set top box.
- ◆ For CATV Optical Receivers and Amplifiers.
- ◆ For VHF/UHF Transmitters and Push-pull Amplifiers.

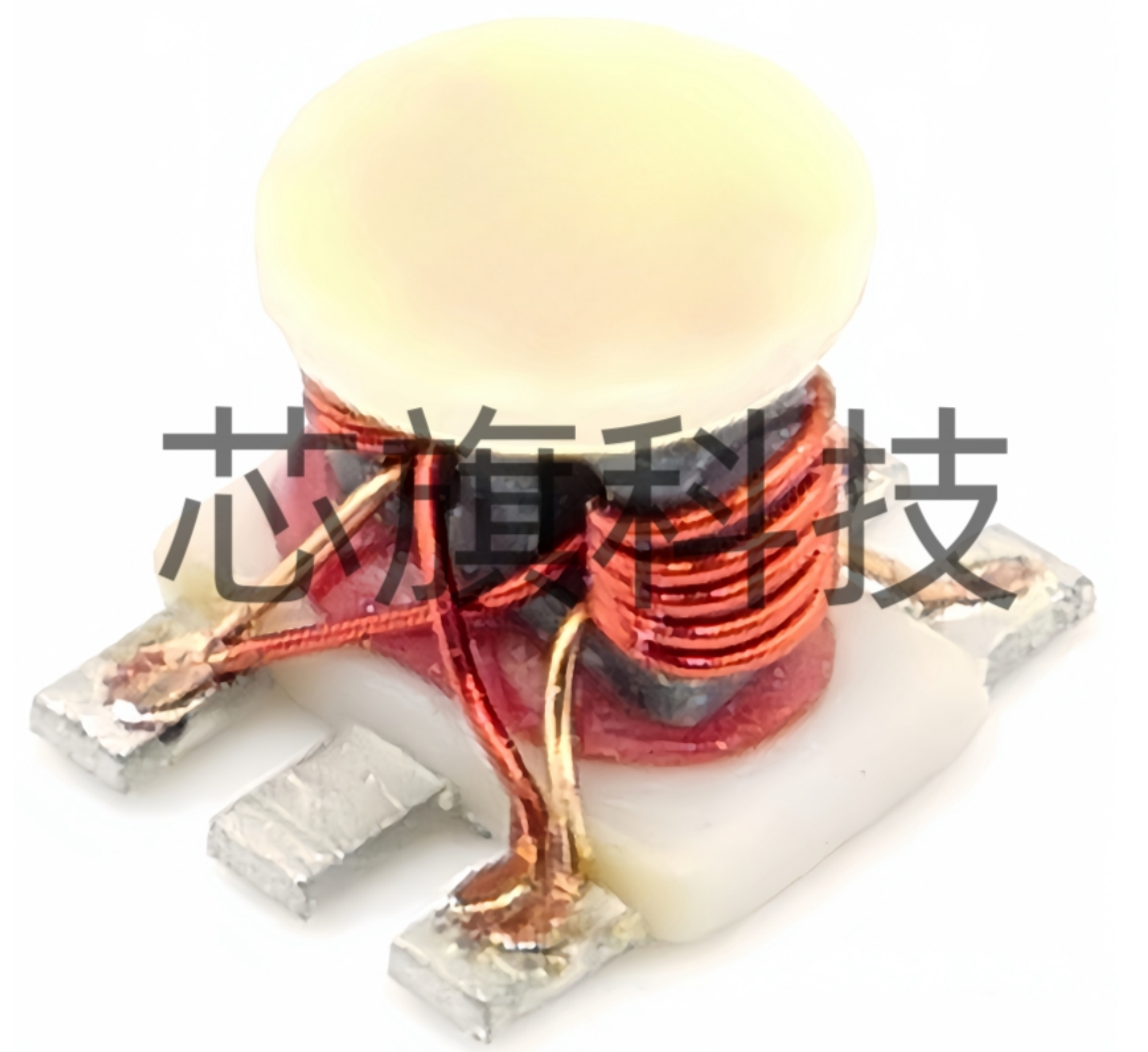

Dimension diagram (Unit:mm) :

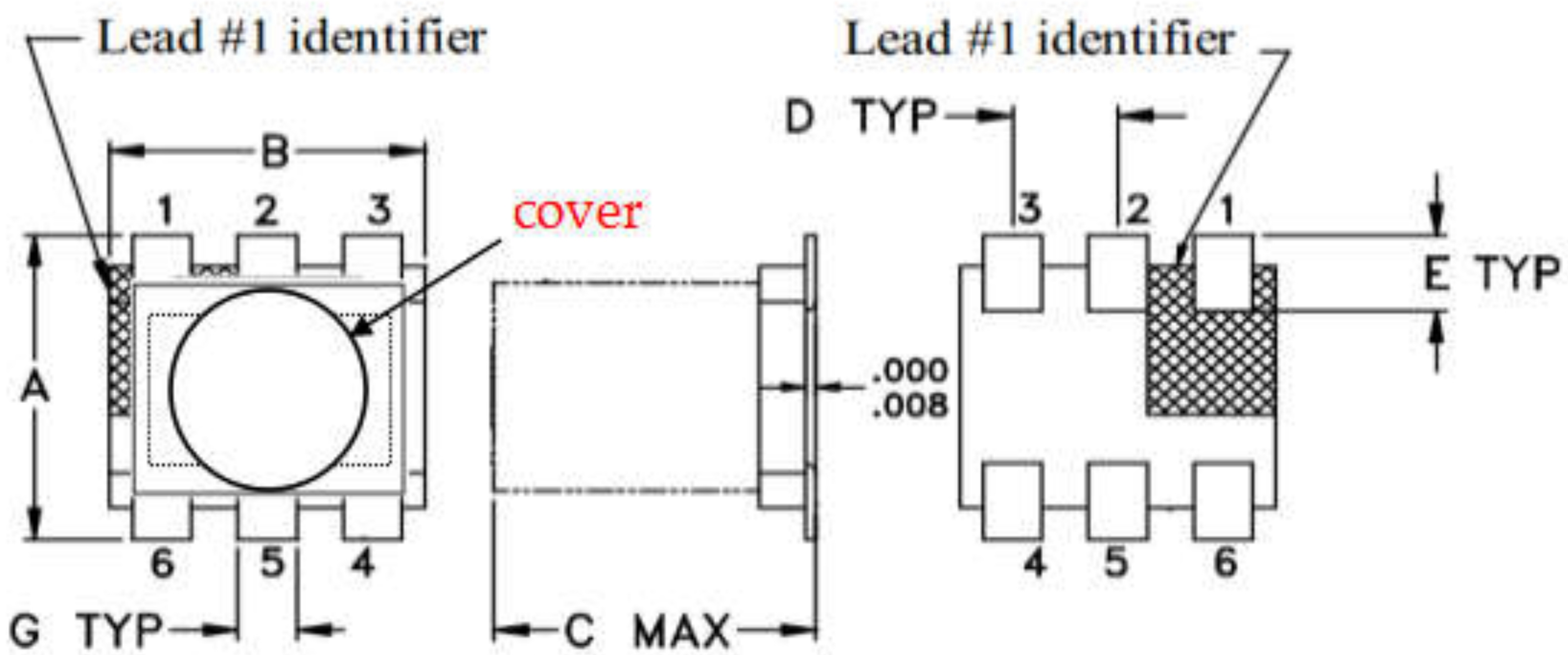

A=4.20±0.20 B=3.80±0.20 C=3.50 Max D=1.27±0.05 E=1.00±0.05

Electrical structure:

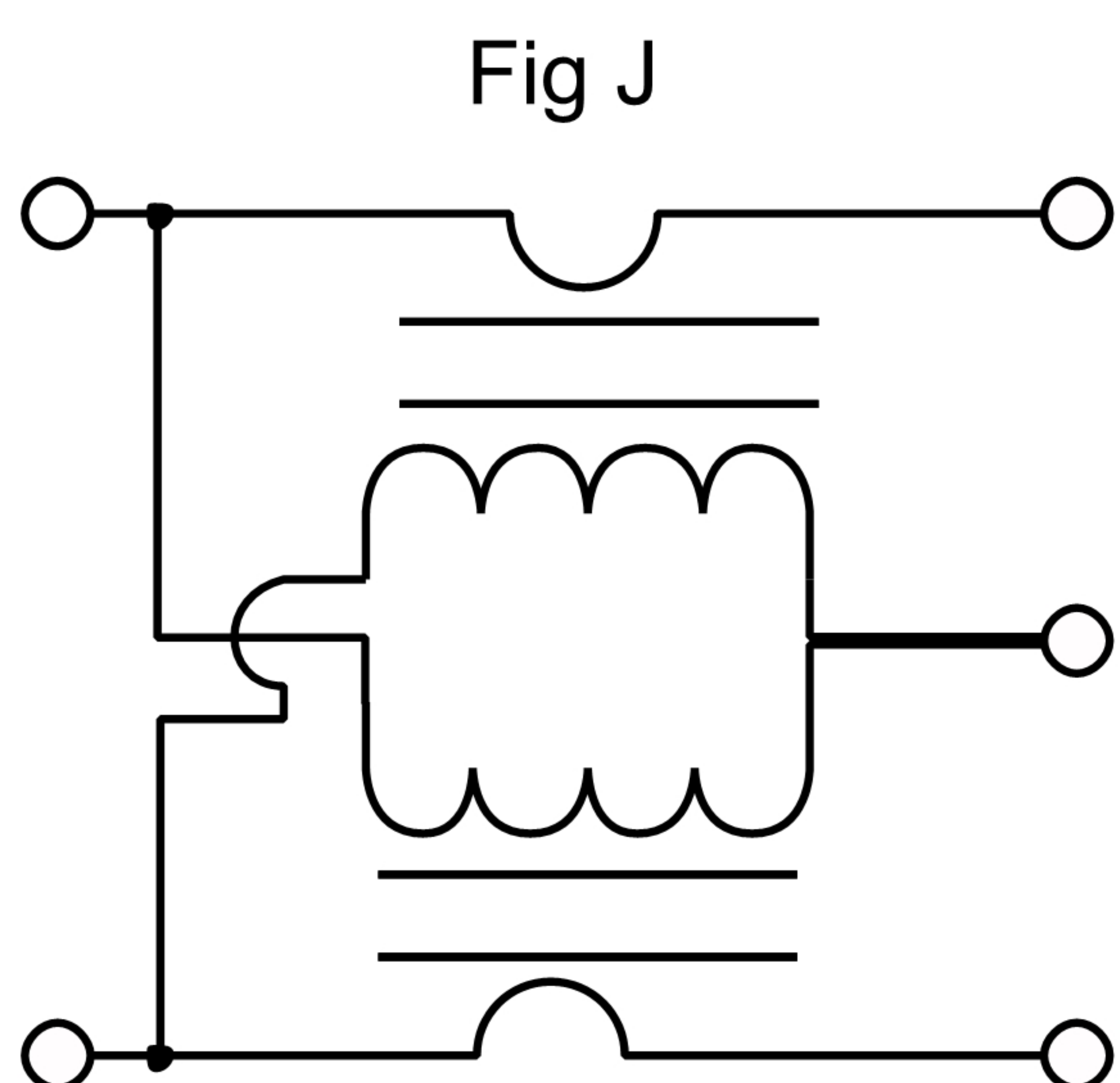

Recommended layout(mm):

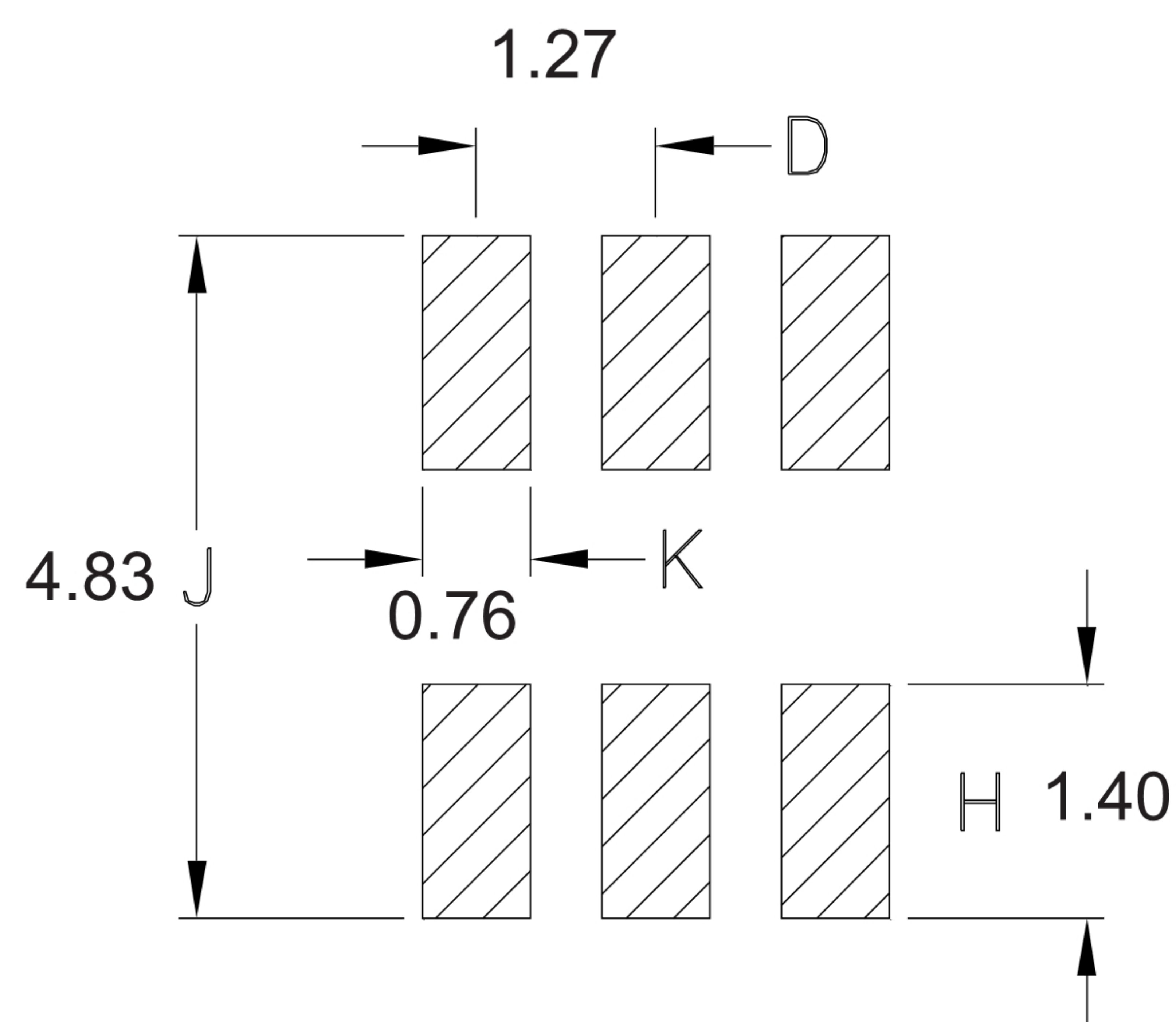

Pin configuration:

Input	3
Coupling	1
Output	4
Ground	2
External 75 Ω	6

Sample test data sheet:

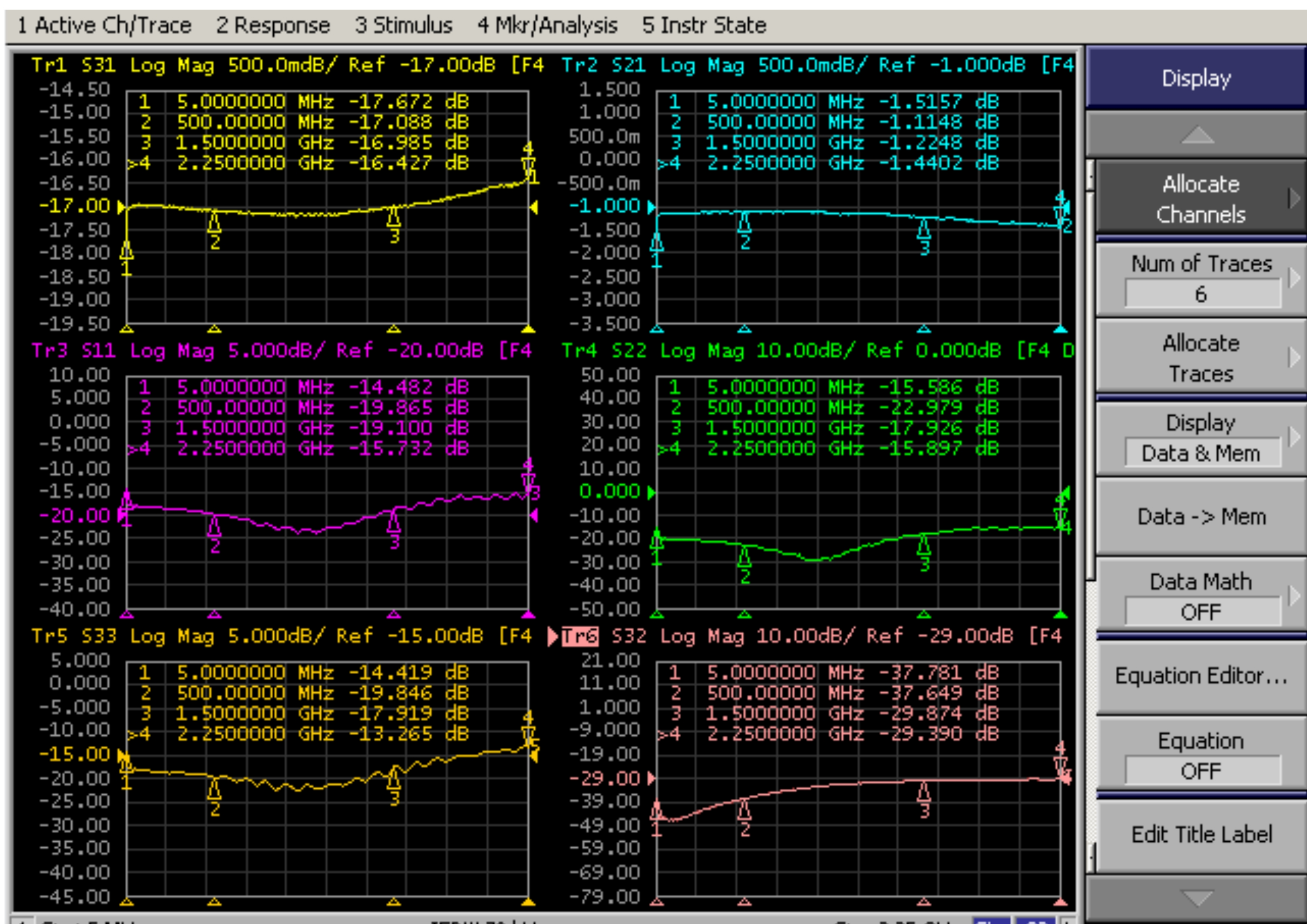

Electrical Specifications: $T_A=25^\circ\text{C}$, 0dBm , $Z_0=75\Omega$:

Parameter	Test Conditions	Units	Min	Typ	Max
Main line Loss	5-2250MHz	dB	—	1.0	2.0
Coupling	5-2250MHz	dB	—	16.5	19.0
Input Return Loss	5-2250MHz	dB	11.0	20.0	—
Output Return Loss	5-2250MHz	dB	12.0	23.0	—
Coupling Return Loss	5-2250MHz	dB	10.0	20.0	—
Isolation	5-2250MHz	dB	22.0	30.0	—