

General Description

HT298 is a high voltage, high current dual full-bridge driver designed to accept standard TTL logic levels and drive inductive loads such as relays, solenoids, DC and stepping motors.

Features

- OPERATING VOLTAGE UP TO 46 V
- TOTAL DC CURRENT UP TO 4 A
- LOW SATURATION VOLTAGE
- LOGICAL "0" INPUT VOLTAGE UP TO 1.5 V
- THE LOGIC POWER SUPPLY AND DRIVE POWER SUPPLY ARE INDEPENDENT OF EACH OTHER

Ordering Information

Product Model	Package Type	Marking	Packing	Packing Qty
HT298P	PowerSO-20	HT298P	Tape	600PCS/Reel
HT298N	Multiwatt-15	HT298N	Tube	250PCS/BOX

Outside View

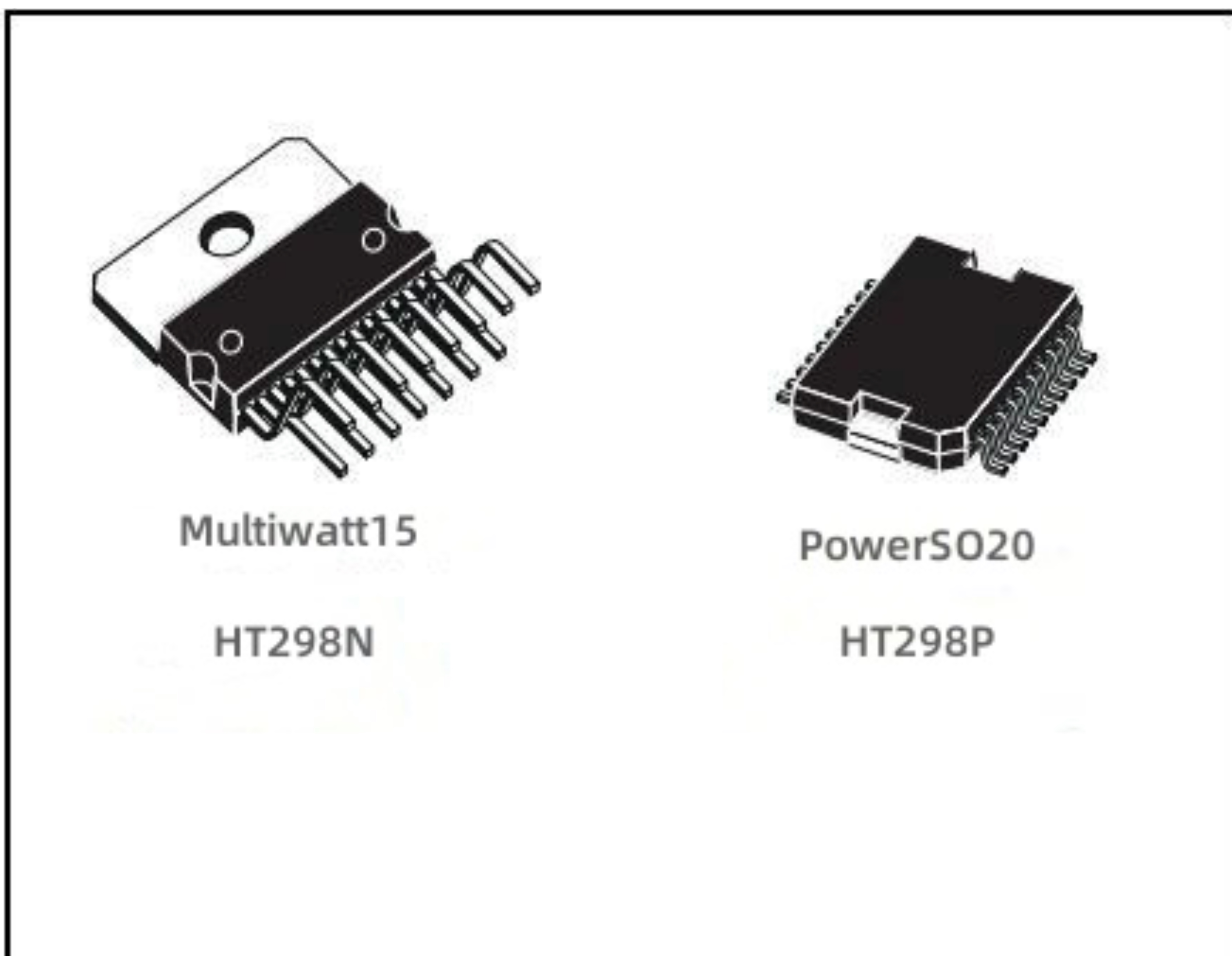

Pin Definition And Function

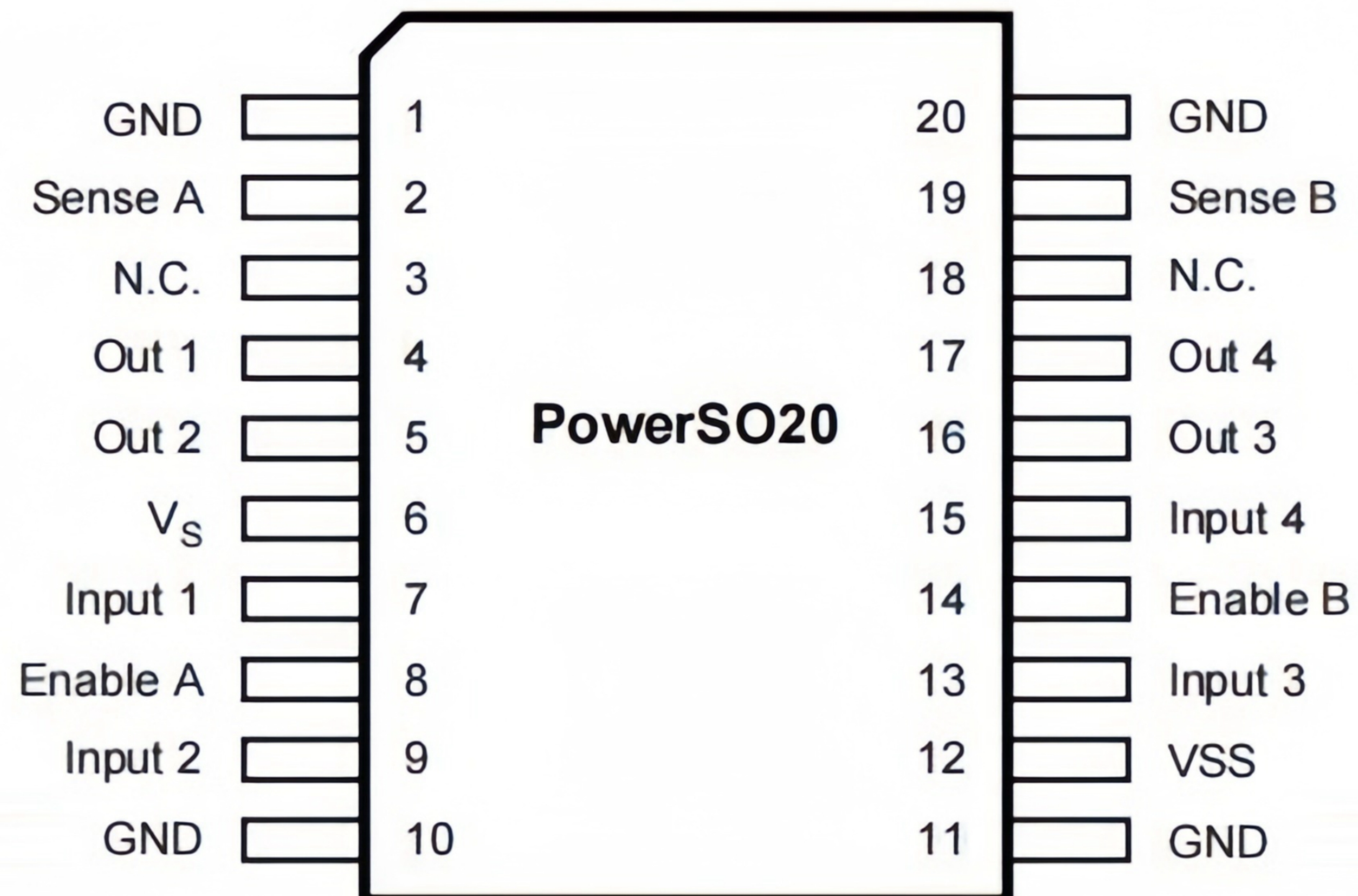
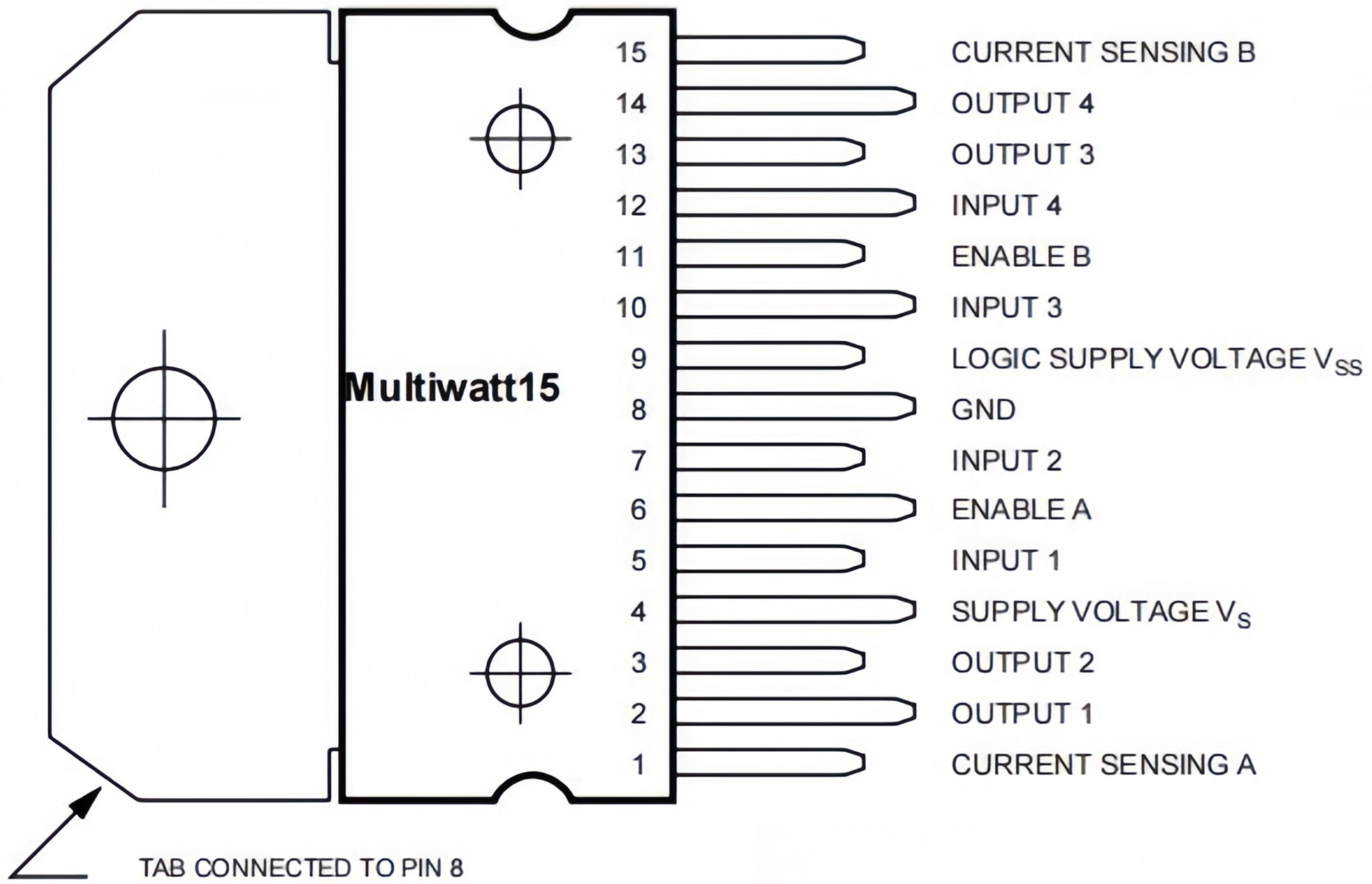

PINS AND DEFINITIONS OF HT298

MW.15	PowerSO	Name	Function
1;15	2;19	Sense A; Sense B	Between this pin and ground is connected the sense resistor to control the current of the load.
2;3	4;5	Out 1; Out 2	Outputs of the Bridge A; the current that flows through the load connected between these two pins is monitored at pin 1.
4	6	V _s	Supply Voltage for the Power Output Stages. A non-inductive 100nF capacitor must be connected between this pin and ground.
5;7	7;9	Input 1; Input 2	TTL Compatible Inputs of the Bridge A.
6;11	8;14	EnableA;Enable B	TTL Compatible Enable Input: the L state disables the bridge A (enable A) and/or the bridge B (enable B).
8	1,10,11,20	GND	Ground.
9	12	VSS	Supply Voltage for the Logic Blocks. A100nF capacitor must be connected between this pin and ground.
10; 12	13;15	Input 3; Input 4	TTL Compatible Inputs of the Bridge B.
13; 14	16;17	Out 3; Out 4	Outputs of the Bridge B. The current that flows through the load connected between these two pins is monitored at pin 15.
	3;18	N.C.	Not Connected

Block Diagram



BLOCK DIAGRAM OF HT298

ABSOLUTE MAXIMUM RATINGS

Symbol	Parameter	Value	Unit
V_S	Power Supply	50	V
V_{SS}	Logic Supply Voltage	7	V
V_I, V_{en}	Input and Enable Voltage	-0.3 to 7	V
I_o	Peak Output Current (each Channel)		
	– Non Repetitive ($t = 100\mu s$)	3	A
	– Repetitive (80% on –20% off; $t_{on} = 10ms$)	2.5	A
	– DC Operation	2	A
V_{sens}	Sensing Voltage	-1 to 2.3	V
P_{tot}	Total Power Dissipation ($T_{case} = 75.0\text{ }^\circ\text{C}$)	25	W
T_{op}	Junction Operating Temperature	-25 to 130	$^\circ\text{C}$
T_{stg}, T_j	Storage and Junction Temperature	-40 to 150	$^\circ\text{C}$

Electrical Characteristics ($V_S = 42V$; $V_{SS} = 5V$, $T_j = 25^\circ\text{C}$; unless otherwise specified)

Symbol	Parameter	Test Conditions	Min.	Typ.	Max.	Unit
V_S	Supply Voltage (pin 4)	Operative Condition	$V_{IH} + 2.5$		46	V
V_{SS}	Logic Supply Voltage (pin 9)		4.5	5	7	V
I_S	Quiescent Supply Current (pin 4)	$V_{en} = H$; $I_L = 0$ $V_i = L$		13	22	mA
				50	70	mA
		$V_{en} = L$ $V_i =$	X		4	mA
I_{SS}	Quiescent Current from V_{SS} (pin 9)	$V_{en} = H$; $I_L = 0$ $V_i = L$		24	36	mA
				7	12	mA
		$V_{en} = L$ $V_i =$	X		6	mA
V_{iL}	Input Low Voltage (pins 5, 7, 10, 12)		-0.3		1.5	V
V_{iH}	Input High Voltage (pins 5, 7, 10, 12)		2.3		V_{SS}	V
I_{iL}	Low Voltage Input Current (pins 5, 7, 10, 12)	$V_i = L$			-10	μA
I_{iH}	High Voltage Input Current (pins 5, 7, 10, 12)	$V_i = H \leq V_{SS} - 0.6V$		30	100	μA
$V_{en} = L$	Enable Low Voltage (pins 6, 11)		-0.3		1.5	V
$V_{en} = H$	Enable High Voltage (pins 6, 11)		2.3		V_{SS}	V
$I_{en} = L$	Low Voltage Enable Current (pins 6, 11)	$V_{en} = L$			-10	μA
$I_{en} = H$	High Voltage Enable Current (pins 6, 11)	$V_{en} = H \leq V_{SS} - 0.6V$		30	100	μA
$V_{CEsat (H)}$	Source Saturation Voltage	$I_L = 1A$	0.95	1.35	1.7	V
		$I_L = 2A$		2	2.7	V
$V_{CEsat (L)}$	Sink Saturation Voltage	$I_L = 1A$ (5)	0.85	1.2	1.6	V
		$I_L = 2A$ (5)		1.7	2.3	V
V_{CEsat}	Total Drop	$I_L = 1A$ (5)	1.80		3.2	V
		$I_L = 2A$ (5)			4.9	V
V_{sens}	Sensing Voltage (pins 1, 15)		-1 (1)		2	V

Application

1 、 POWER OUTPUT STAGE

The HT298 integrates two power output stages (A ; B).The power output stage is a bridge onfiguration and its outputs can drive an inductive load in common or differenzial mode, depending on the state of the inputs.

The current that flows through the load comes out from the bridge at the sense output : an external resistor (RSA ; RSB.) allows to detect the intensity of this current.

2 、 INPUT STAGE

All the inputs are TTL compatible

3 、 POWER

A non inductive capacitor, usually of 100 nF, must be foreseen between both Vs and Vss, to ground, as near as possible to GND pin.The en terminal shall be in L state before the output protection is turned off and on.

4 、 OUTPUT PROTECTION

The fast diode shall be selected as the output protection when driving inductive load. When $I = 2 \text{ A}$, $V_F \leq 1.2\text{V}$, $\text{TRR} \leq 200 \text{ ns}$.

5 、 PARALLEL CONNECTION

When the driving current is greater than 2A, two groups can be connected in parallel for current expansion.

Package

Multiwatt15/ZIP-15

DIM.	mm			inch		
	MIN.	TYP.	MAX.	MIN.	TYP.	MAX.
A			5			0.197
B			2.65			0.104
C			1.6			0.063
D		1			0.039	
E	0.49		0.55	0.019		0.022
F	0.66		0.75	0.026		0.030
G	1.02	1.27	1.52	0.040	0.050	0.060
G1	17.53	17.78	18.03	0.690	0.700	0.710
H1	19.6			0.772		
H2			20.2			0.795
L	21.9	22.2	22.5	0.862	0.874	0.886
L1	21.7	22.1	22.5	0.854	0.870	0.886
L2	17.65		18.1	0.695		0.713
L3	17.25	17.5	17.75	0.679	0.689	0.699
L4	10.3	10.7	10.9	0.406	0.421	0.429
L7	2.65		2.9	0.104		0.114
M	4.25	4.55	4.85	0.167	0.179	0.191
M1	4.63	5.08	5.53	0.182	0.200	0.218
S	1.9		2.6	0.075		0.102
S1	1.9		2.6	0.075		0.102
Dia1	3.65		3.85	0.144		0.152

外观及尺寸

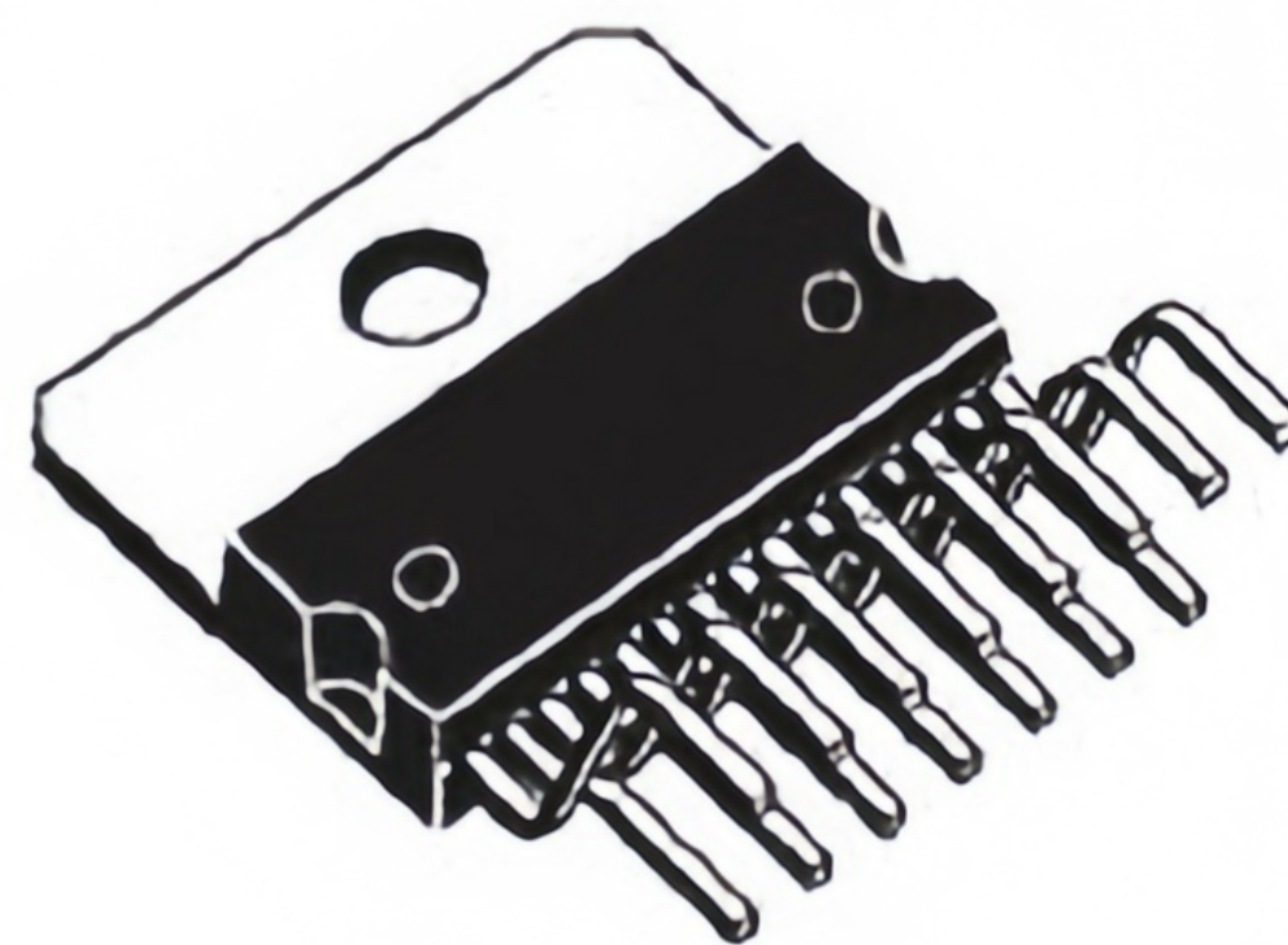

Multiwatt15

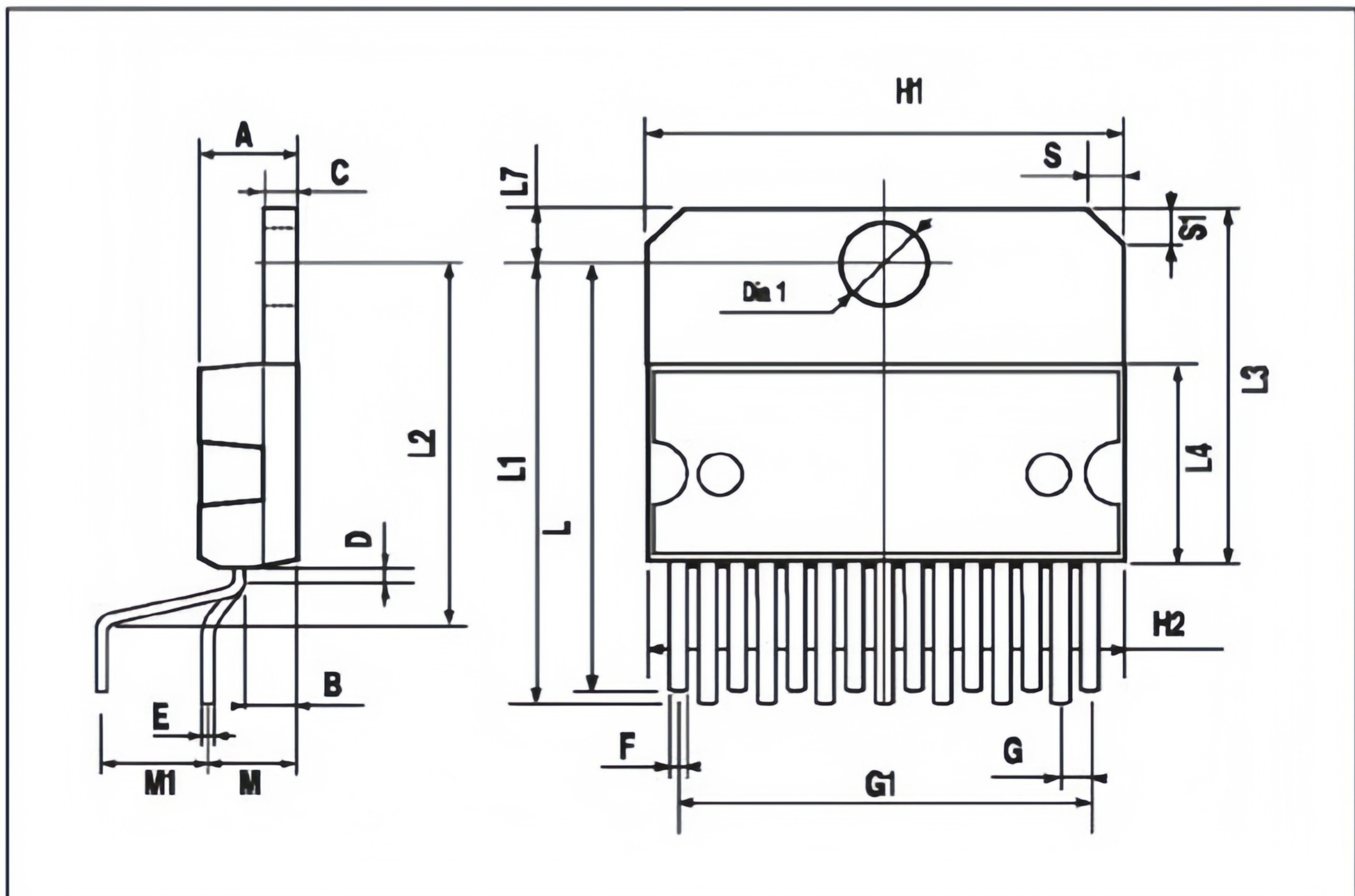

PowerSO-20/HSOP-20

