

Features::

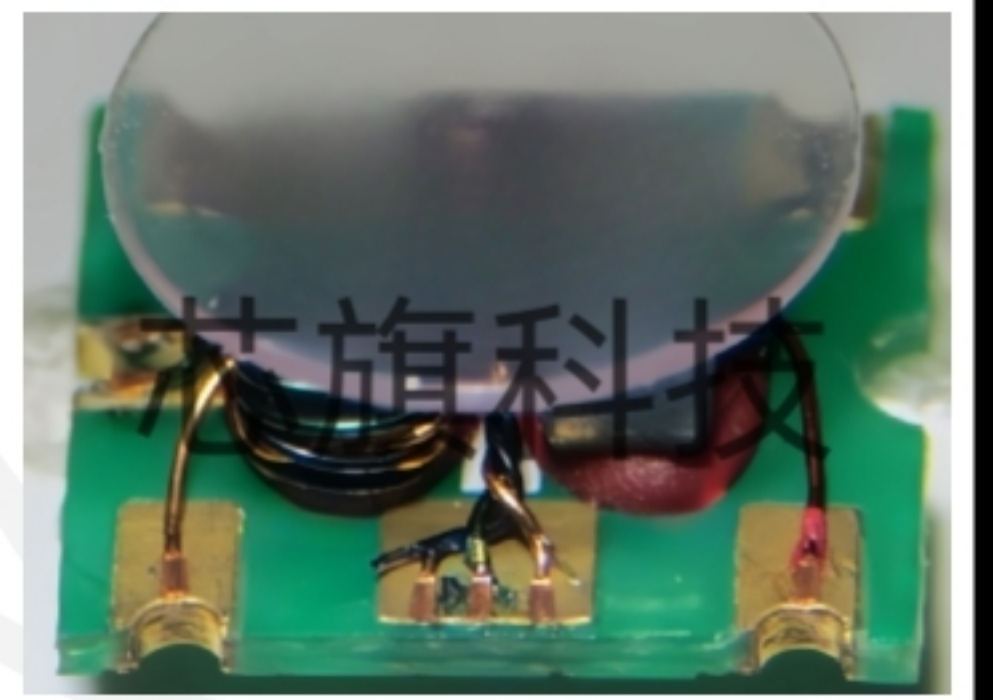

- ◆ 1: 2 Impedance
- ◆ 75Ω Characteristic Impedance
- ◆ Frequency: 5 to 1250 MHz
- ◆ RF power: 0.50W
- ◆ Operating temperature range: -40°C to +85°C
- ◆ Storage temperature range: -55°C to +100°C

Applications:

- ◆ For broadband and wireless communications
- ◆ For VHF/UHF receivers/transmitters and push-pull amplifiers

Dimension Diagram :

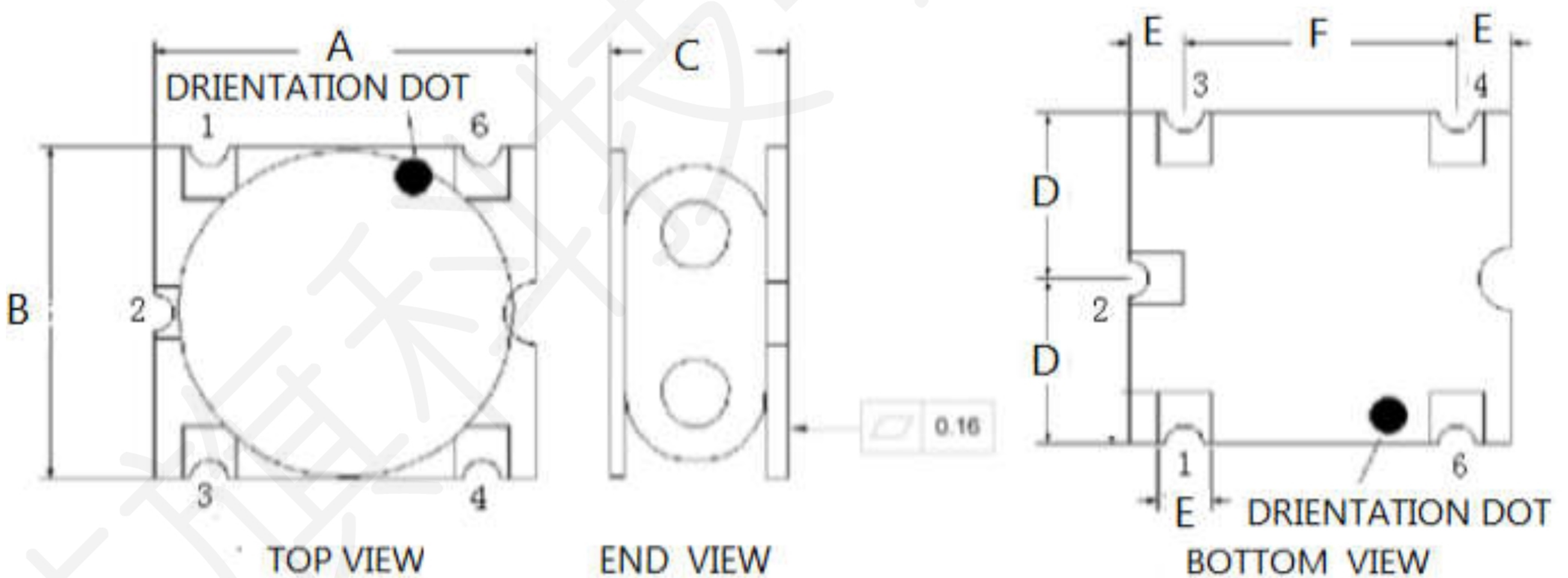

A:7.10±0.20 B:6.30±0.20 C:3.40±0.20 D:3.15±0.15 E:1.00±0.10 F:5.08±0.20

Electrical structure:

Recommended layout:

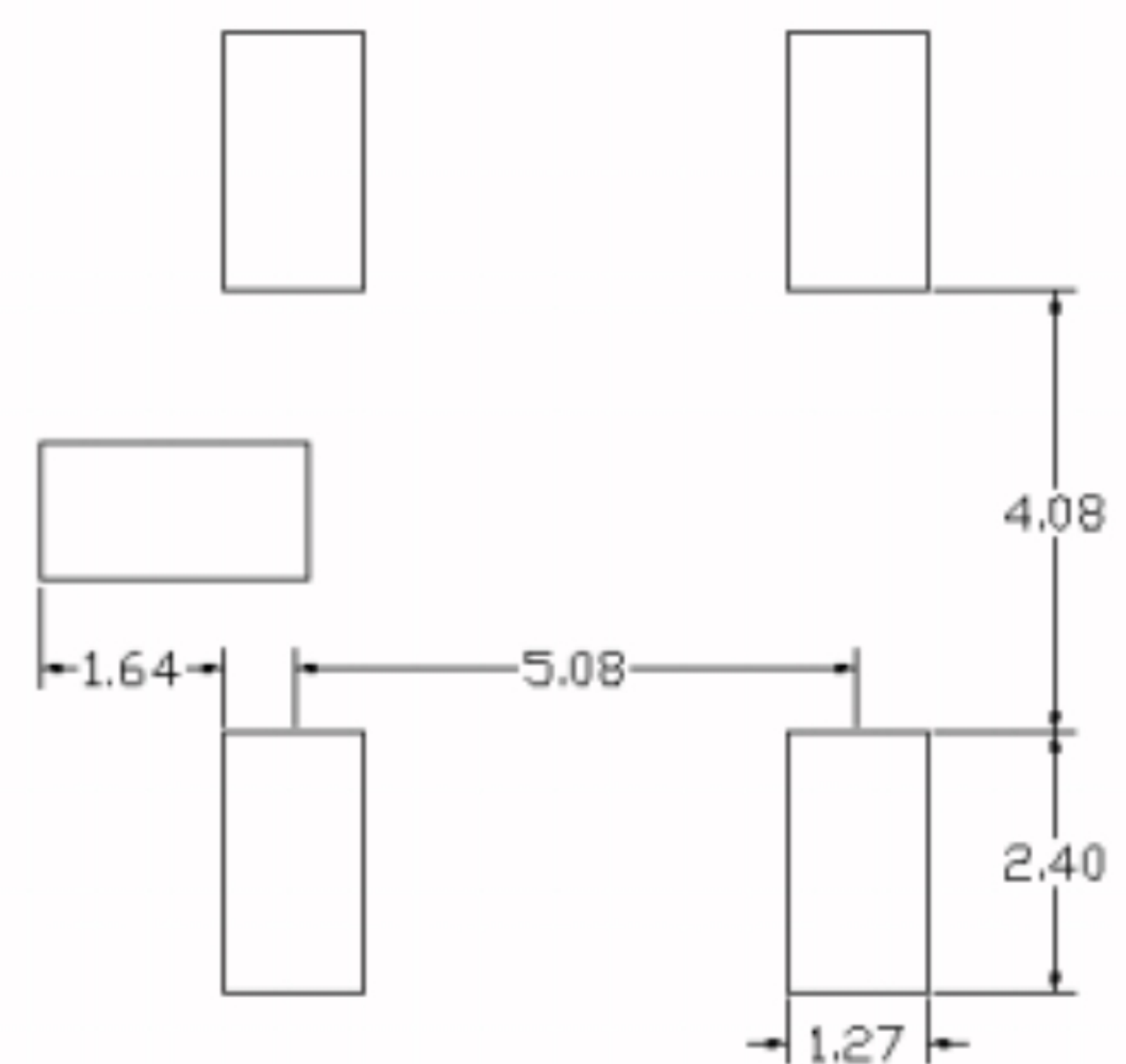
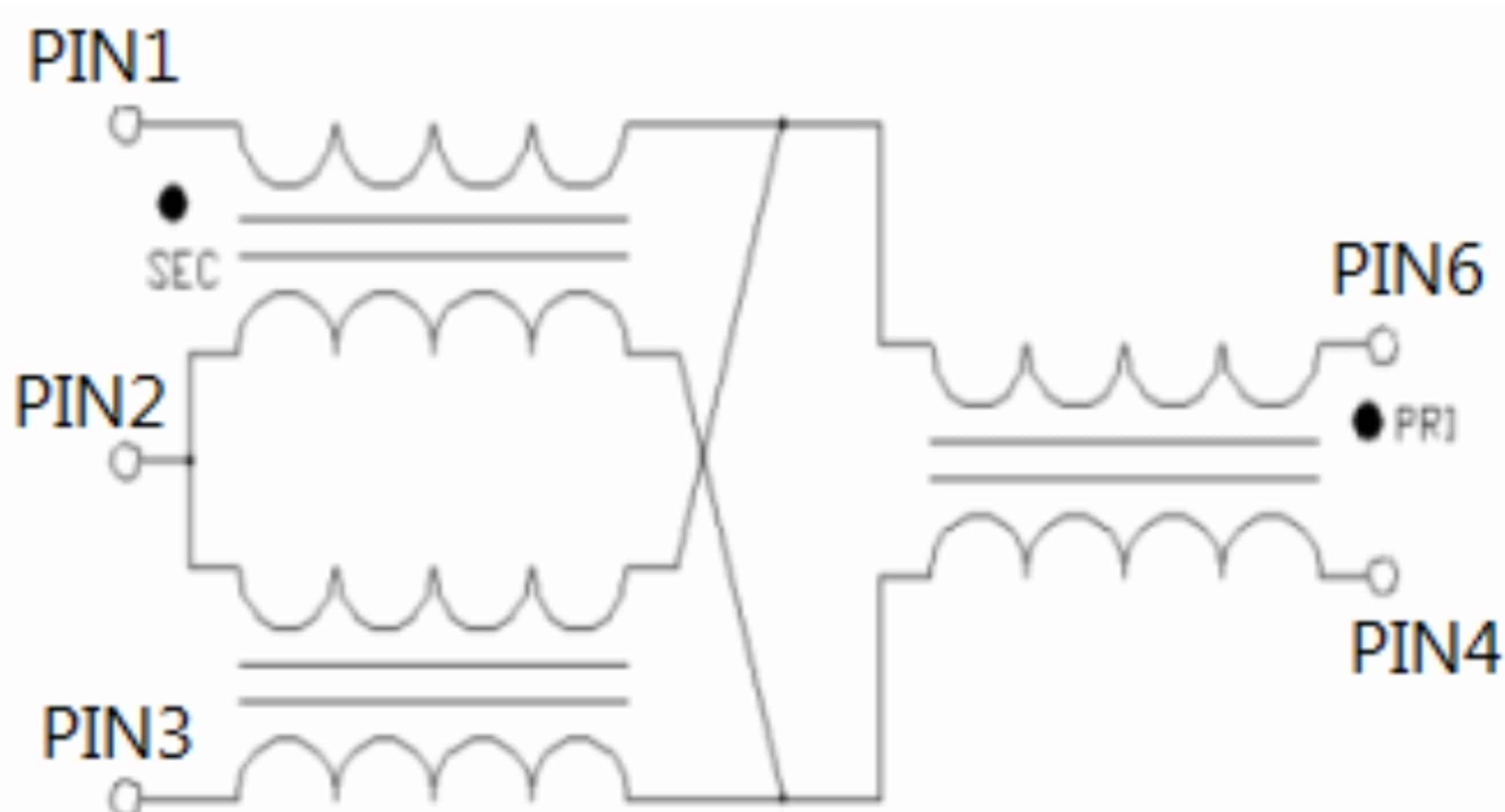

Pin configuration

Application circuit :



Pin no.	Function
1	Secondary dot (Output 1)
2	Centre tap (Ground)
3	Secondary (Output 2)
4	Primary (Ground)
6	Primary dot (Input)

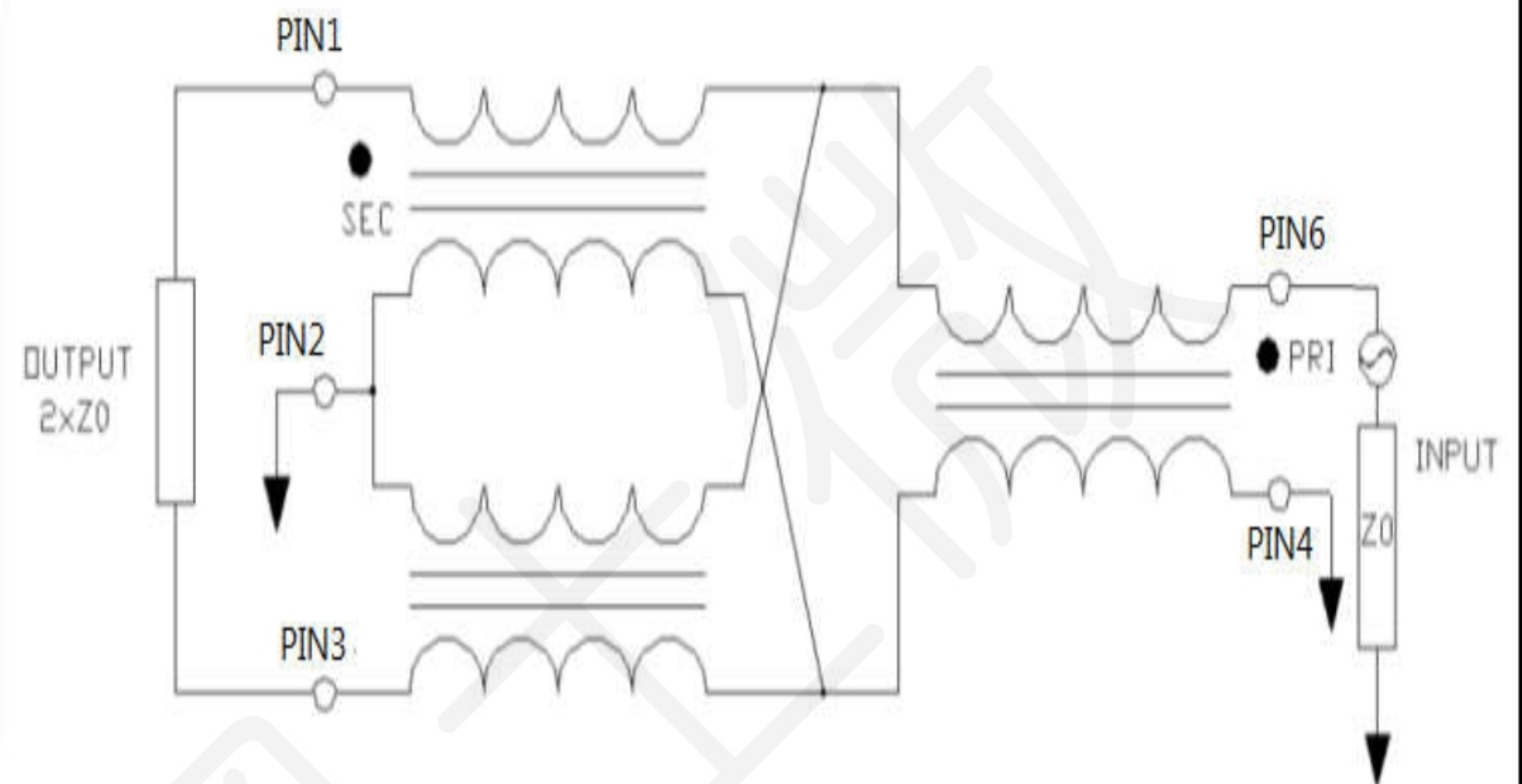

Electrical Specifications: $T_A = 25^\circ C$ $Z_0 = 75\Omega$

Parameter	Test Conditions	Units	Min	Typ	Max
Frequency Range	—	MHz	5	—	1250
Impedance	—	Ω	—	75	—
Impedance Ratio	—	—	—	1:2	—
Insertion Loss1 (Pin 6 to pin 1)	5-50MHz	dB	—	0.40	0.50
	50-400MHz		—	0.50	0.70
	400-1000MHz		—	1.20	2.00
	1000-1250MHz		—	2.00	3.00
Insertion Loss 2 (Pin 6 to pin 3)	5-50MHz	dB	—	0.50	0.60
	50-400MHz		—	0.60	0.80
	400-1000MHz		—	2.00	2.50
	1000-1250MHz		—	2.50	3.50
Amplitude Balance	5-50MHz	dB	-0.30	0.19	0.30
	50-400MHz		-0.60	0.20	0.60
	400-1250MHz		-2.00	0.50	2.0
Phase Balance	5-50MHz	°	-2.00	0.50	2.00
	50-400MHz		-6.00	5.00	6.00
	400-1250MHz		-10.00	8.00	10.00
Input Return Loss (Pin6)	5-50MHz	dB	20.00	25.00	—
	50-400MHz		20.00	25.00	—
	400-1000MHz		18.00	25.00	—
	1000-1250MHz		16.00	20.00	—

RF Balun Transformer, 1: 2 Transmission Line Transformer 5-1250 MHz



Main line Loss(out1)

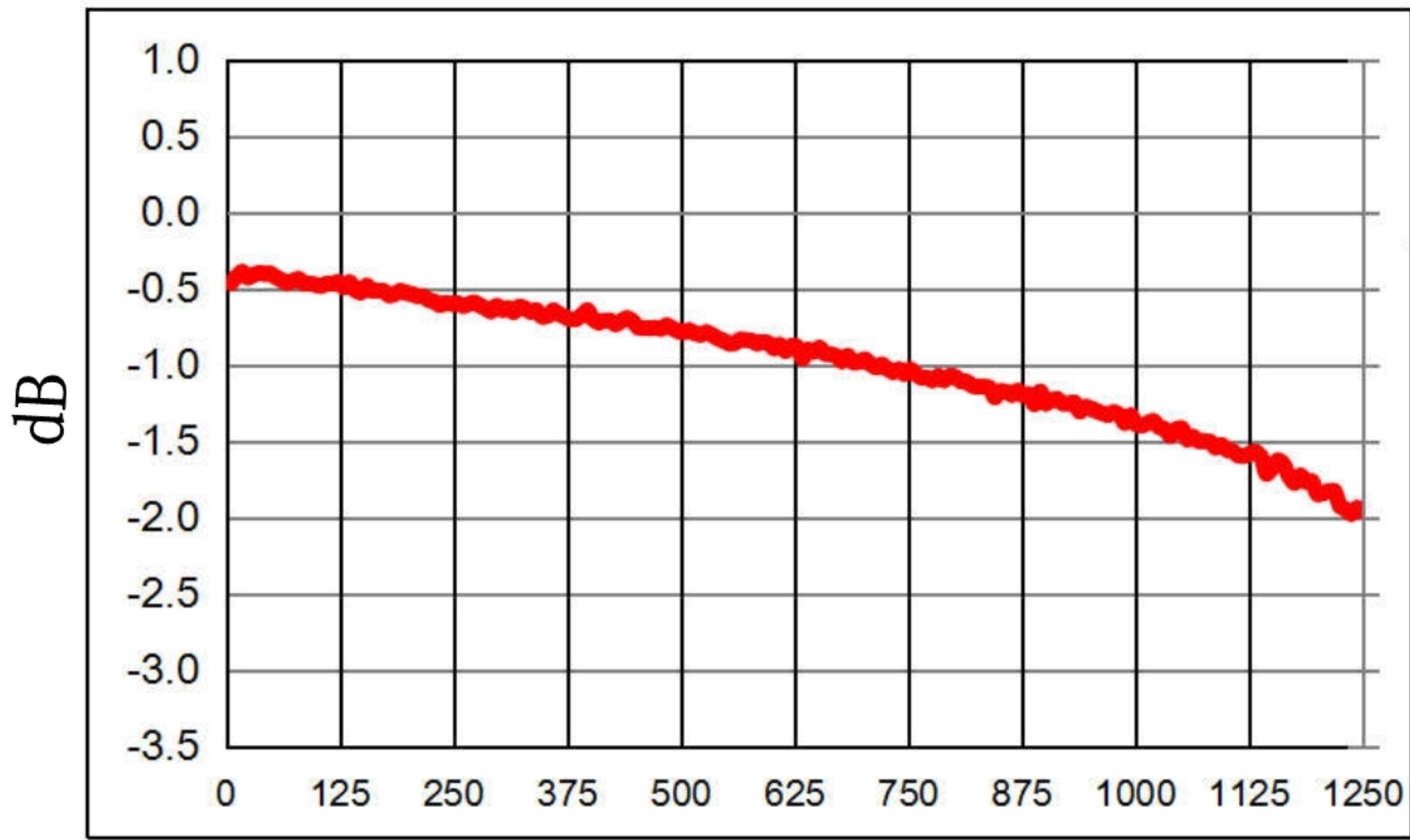

Frequency(MHz)

Main line Loss(out2)

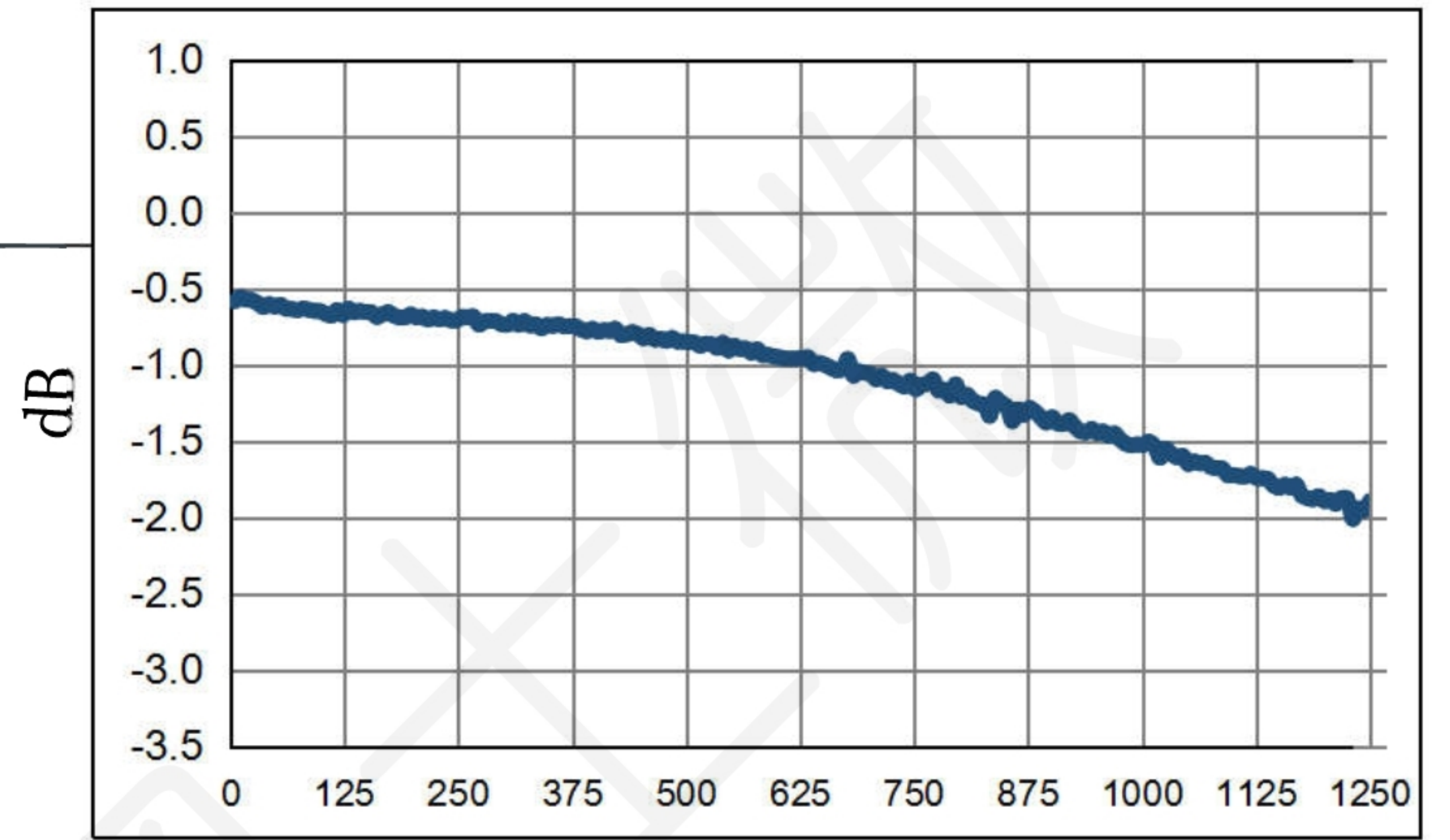

Frequency(MHz)

Amplitude Balance

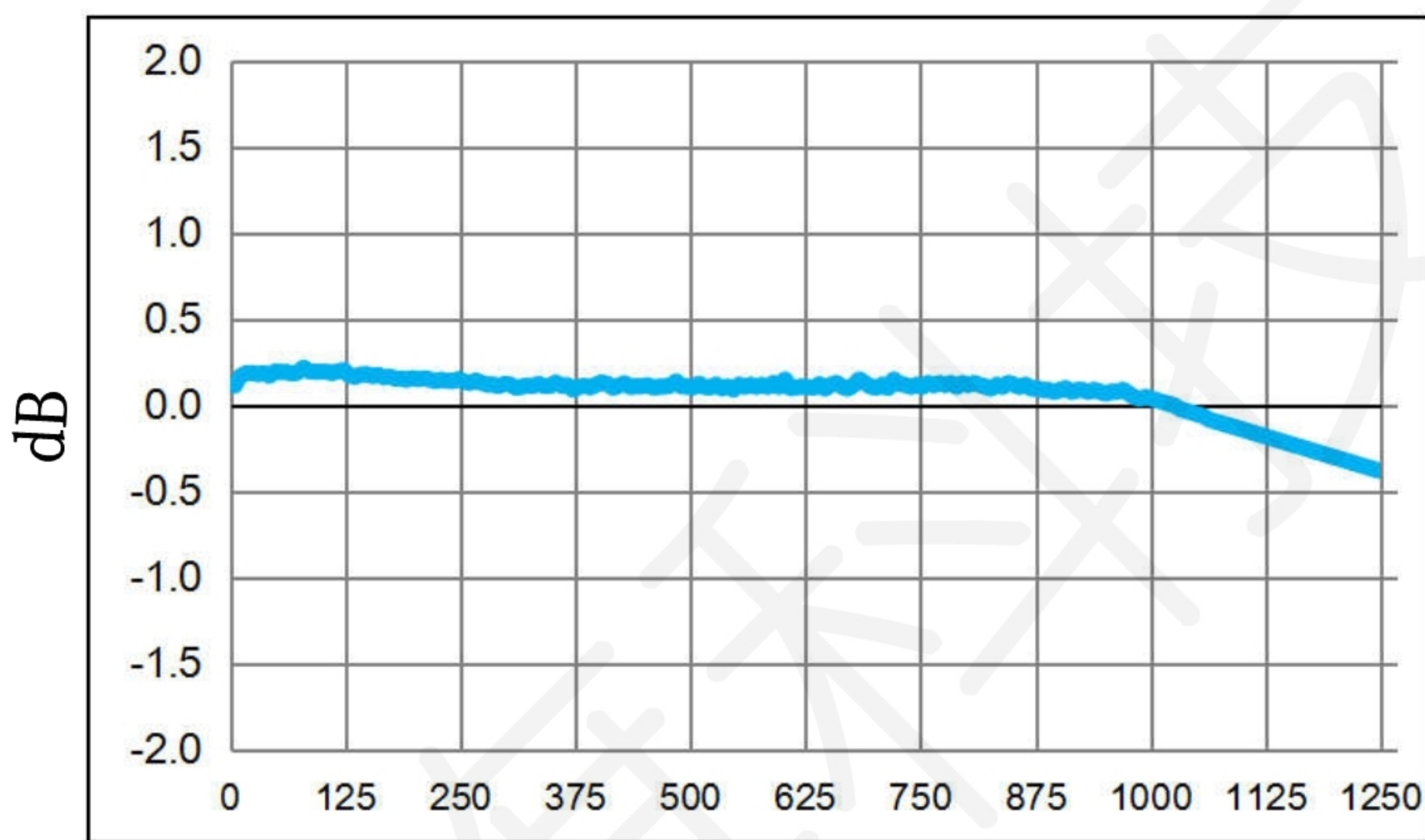

Frequency(MHz)

Phase Balance

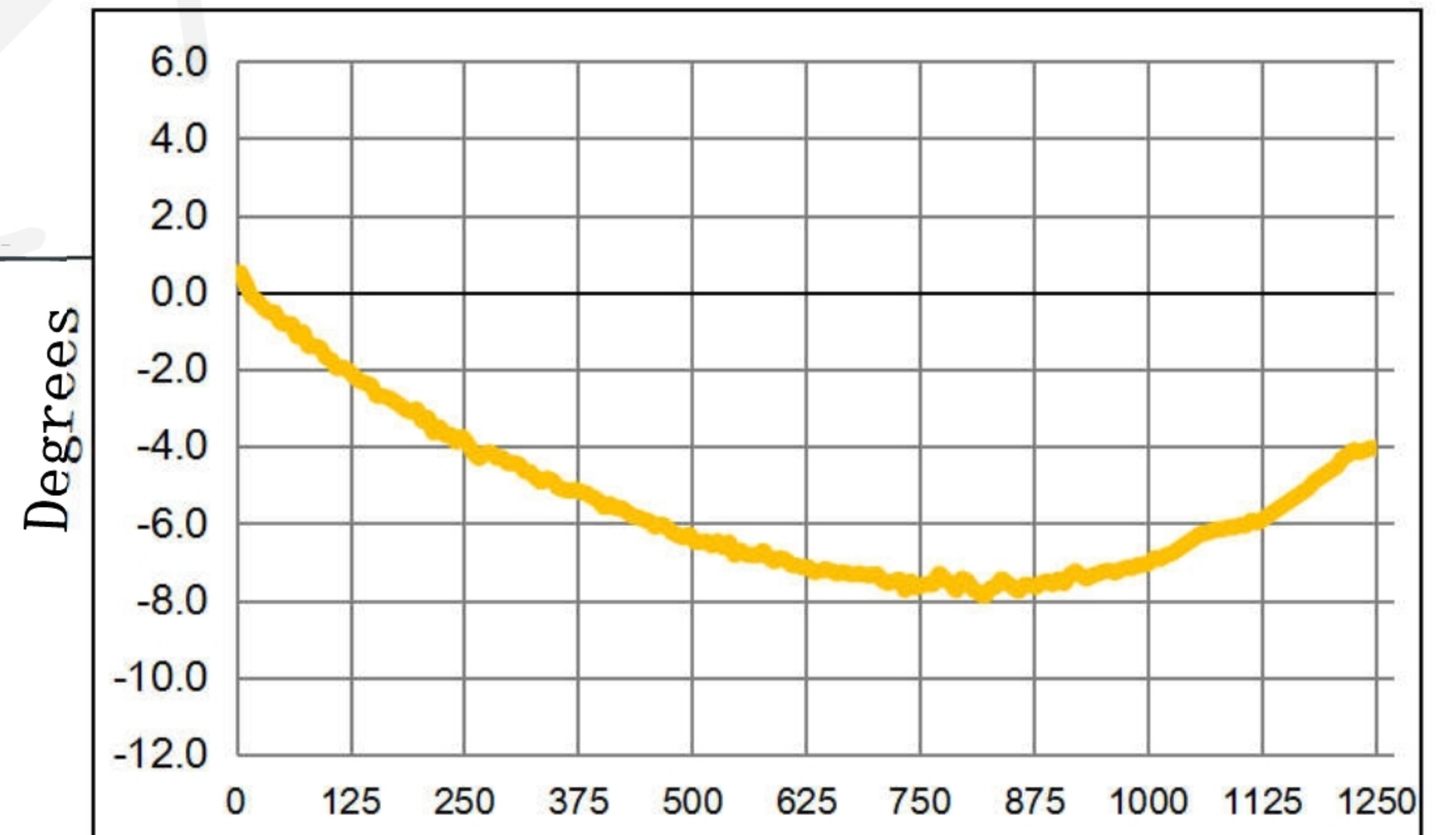

Frequency(MHz)

Input Return Loss

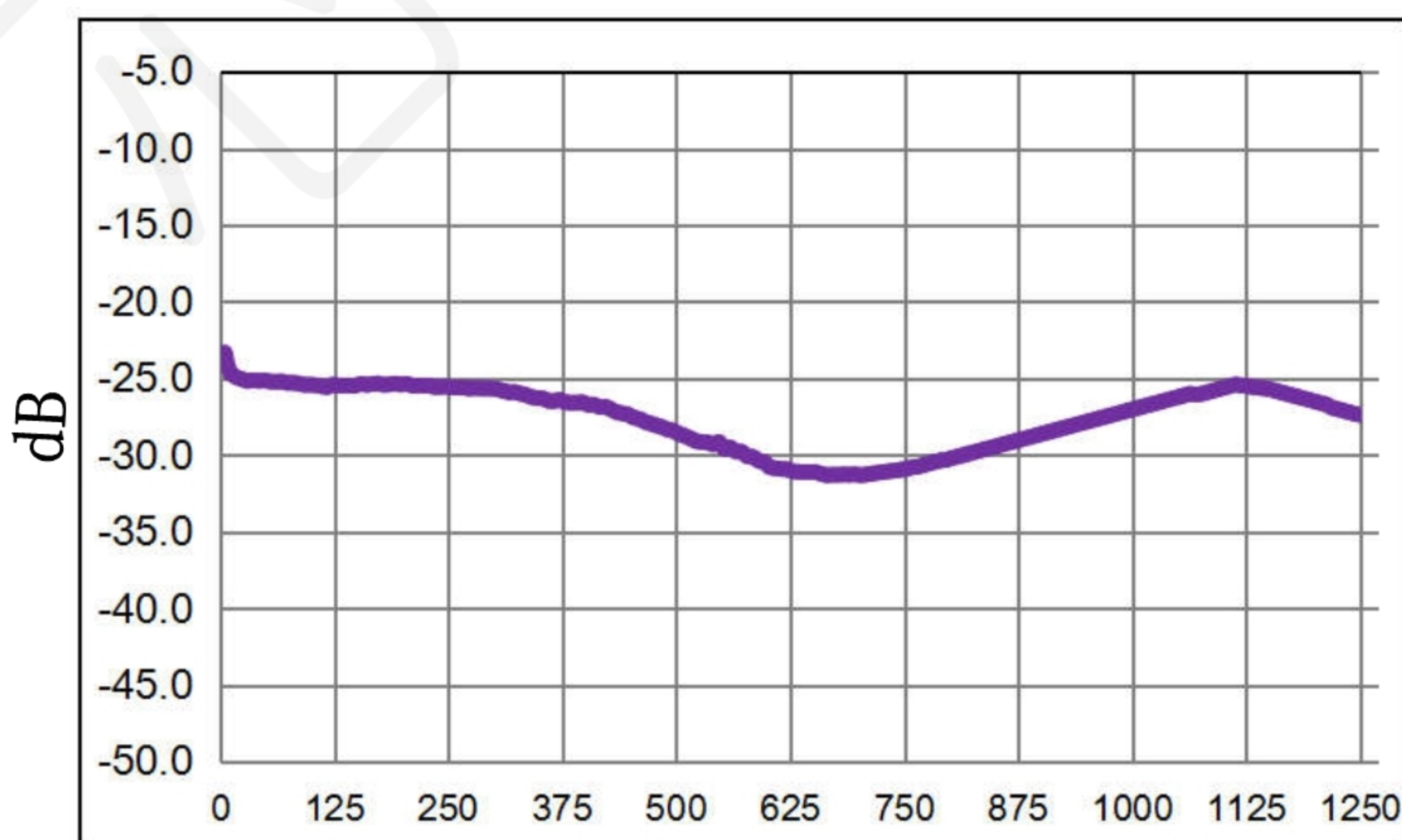

Frequency(MHz)

Sdd22

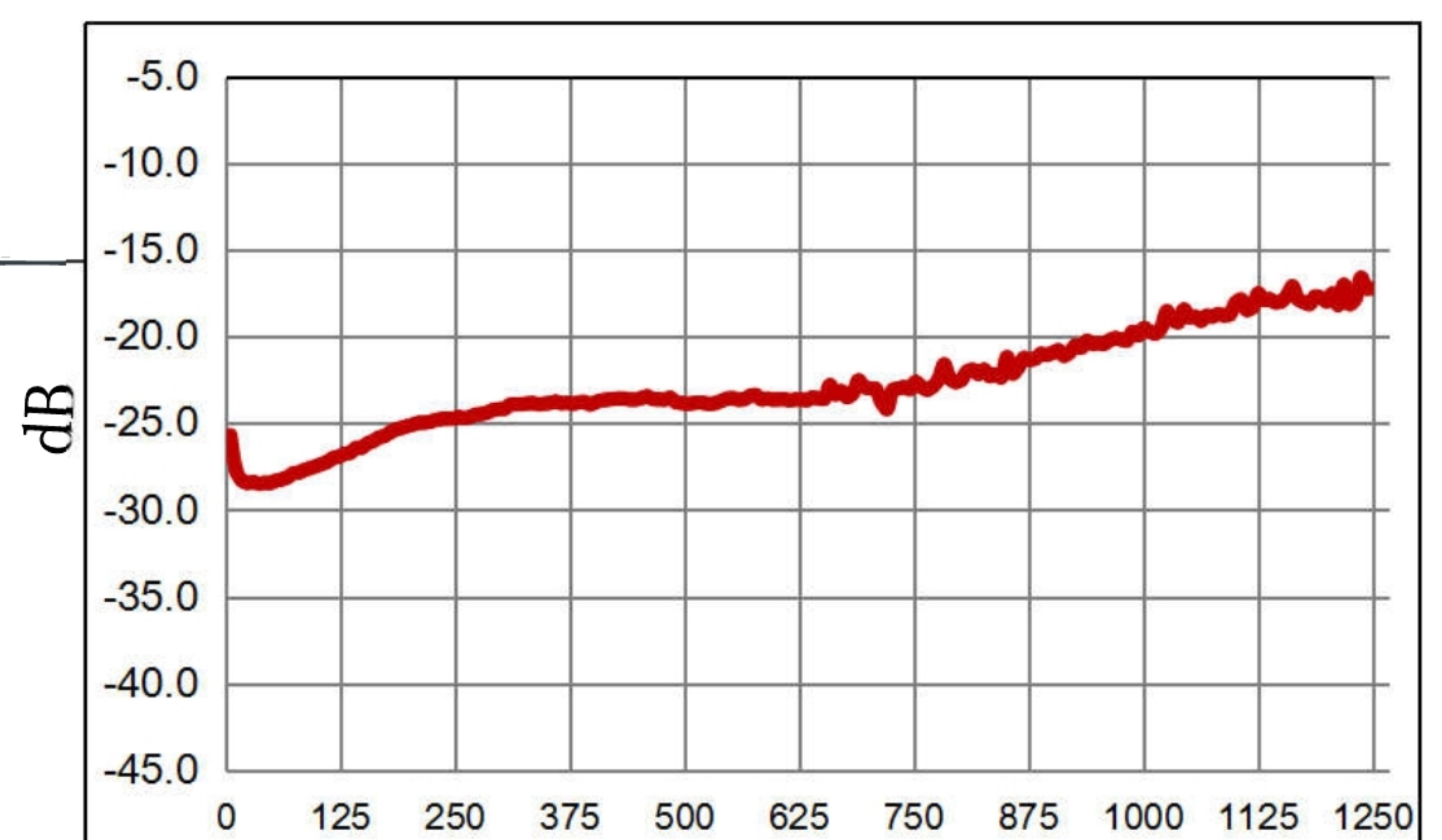

Frequency(MHz)

Recommended Soldering Temperature Graph:



Typical RoHS Reflow Profile

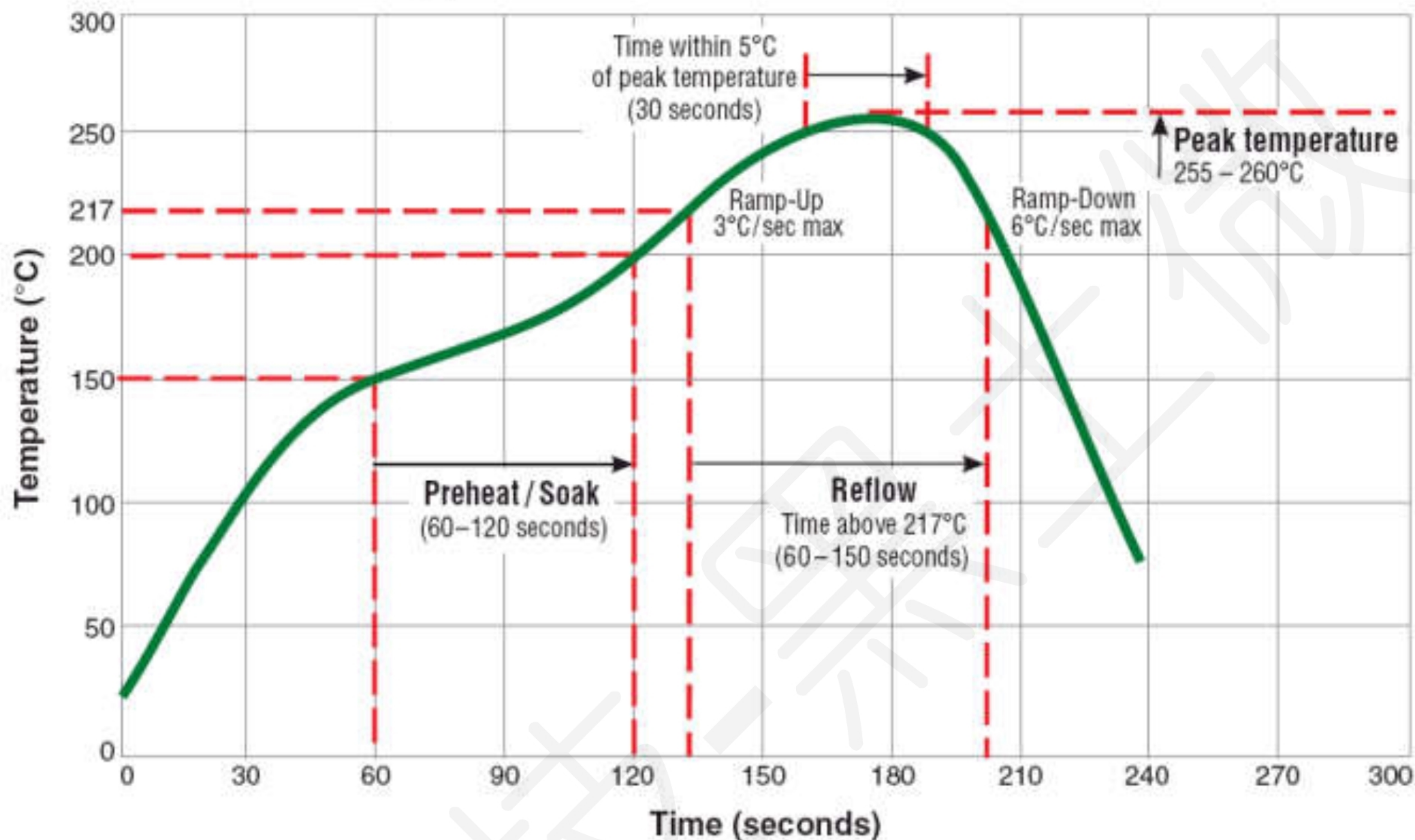

Packing Dimension For Caeier Tape(UNIT:mm):

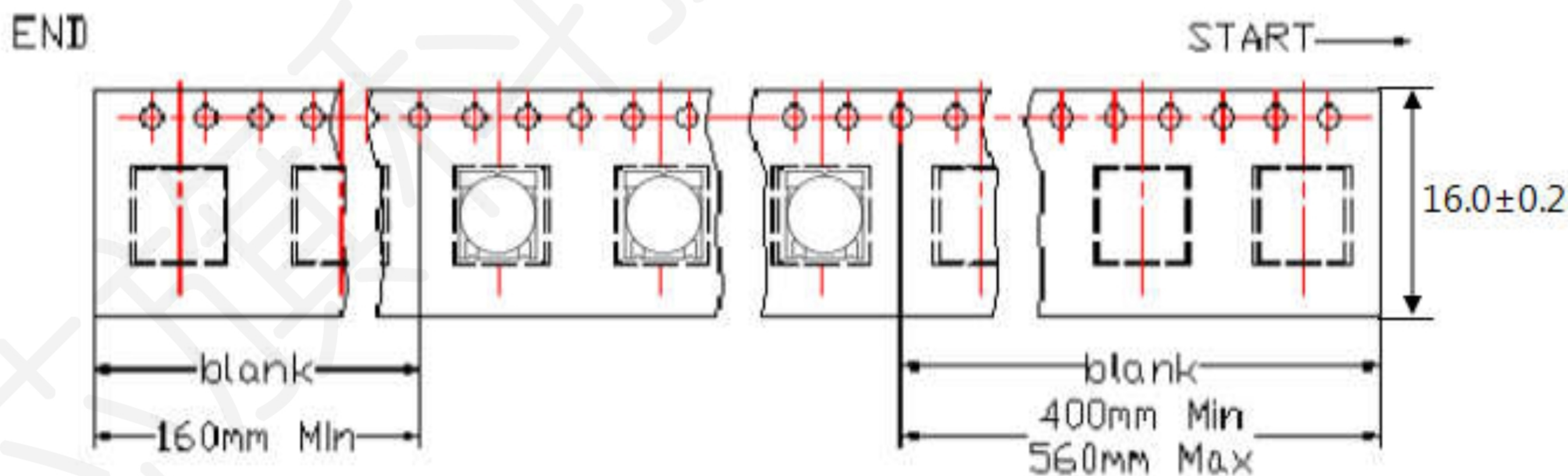

QUANTITY
1500PCS/Reel
3Reels/Middle Carton Middle Carton:
4 Middle Cartons/Big Carton
18000PCS/ Big Carton

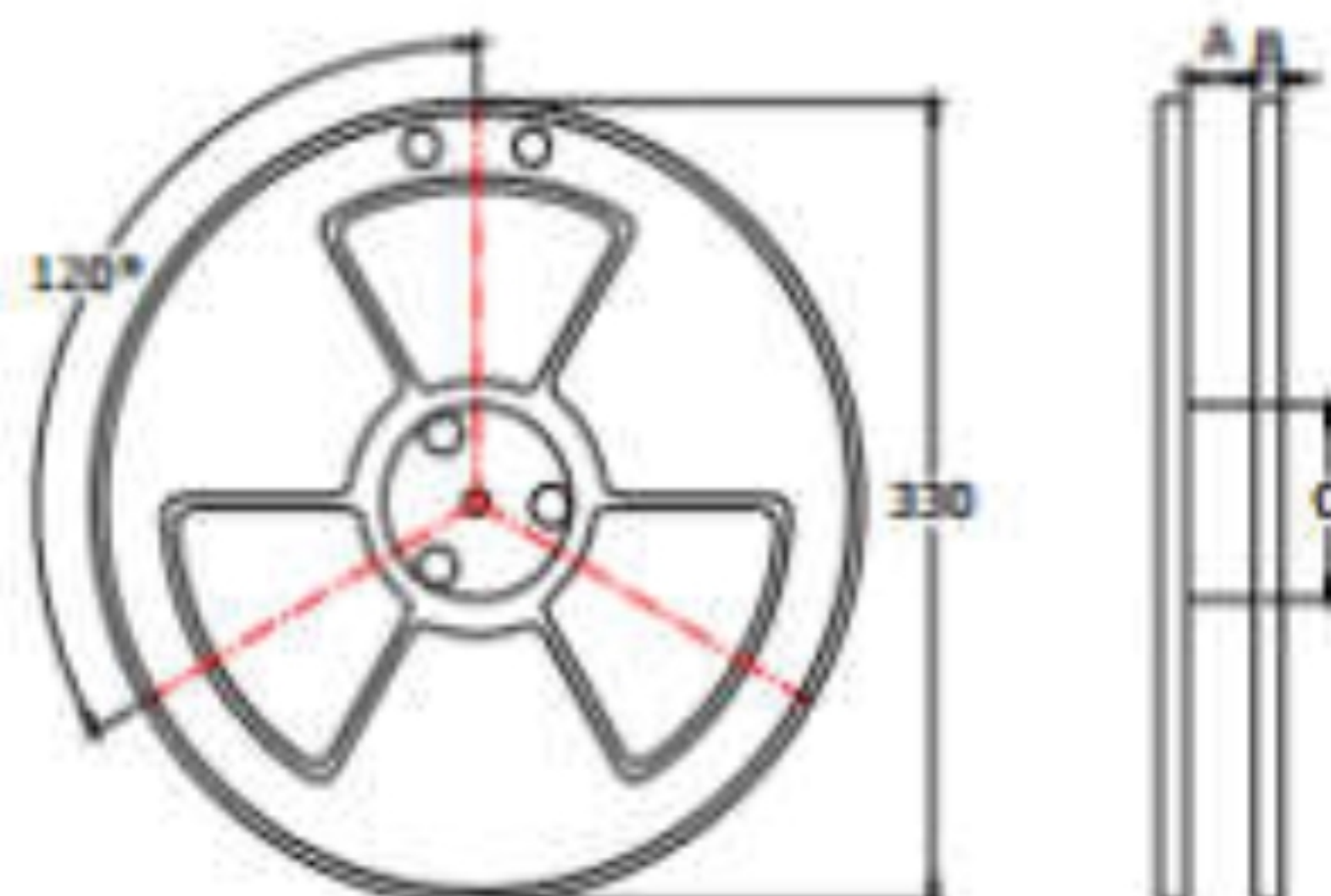

SPEC	8	12	16	24
DIM A±0.1	8.5	12.5	16.5	24.5
DIM B±0.1	2.3	2.3	2.3	2.3
DIM C±0.1	100	100	100	100

