

RF Balun Transformer HTW-1064



75Ω 4:1 CT Flux Coupled Transformer 5-300 MHz



Outline Drawing(mm)

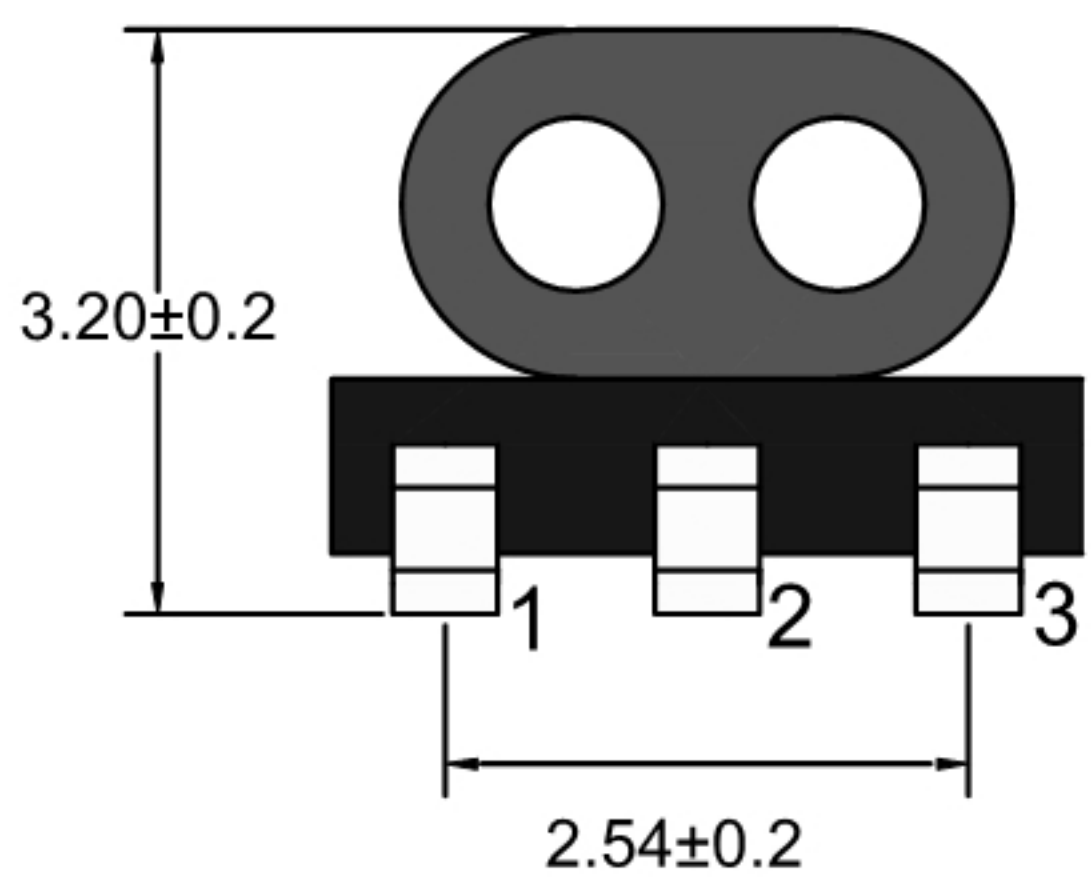
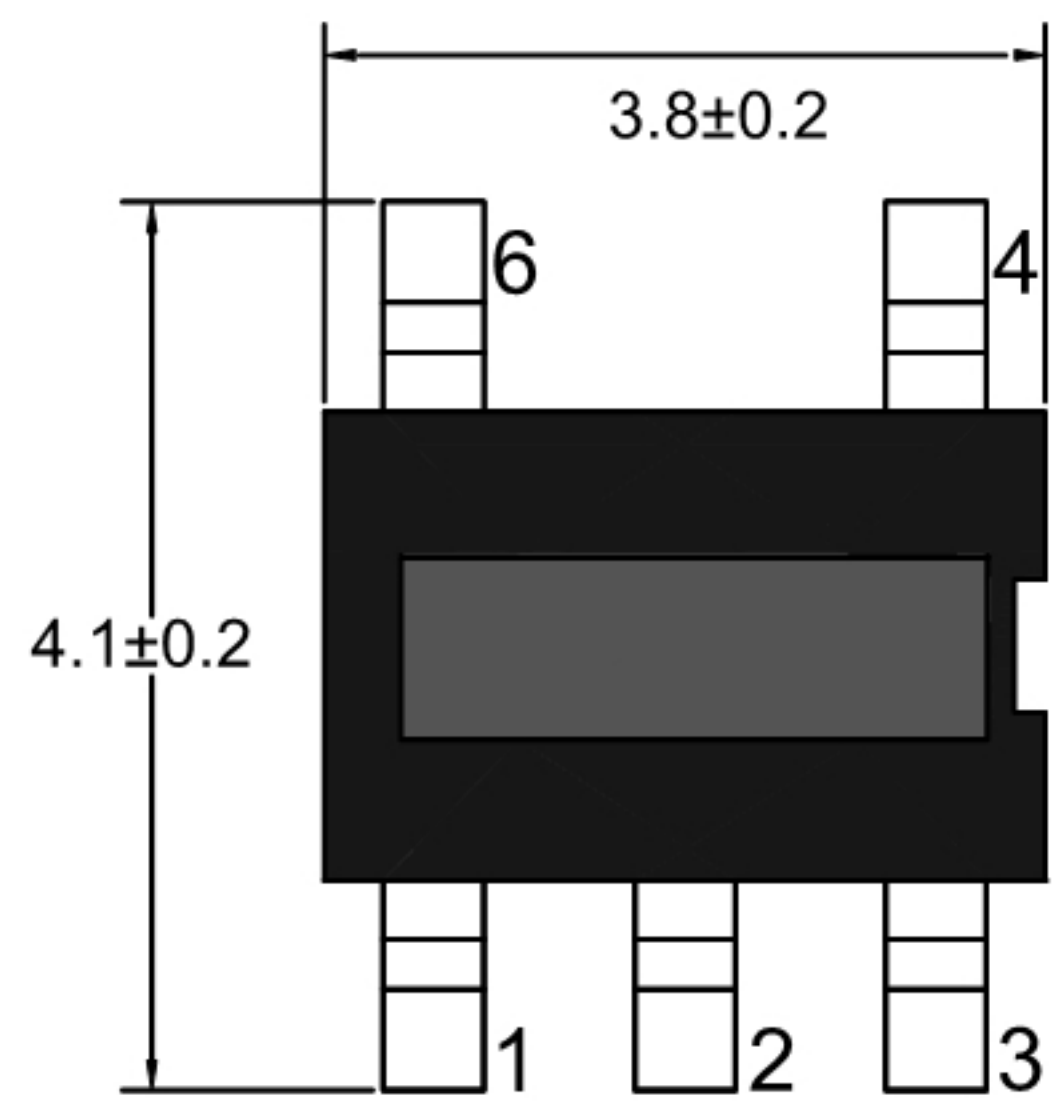

Electrical structure

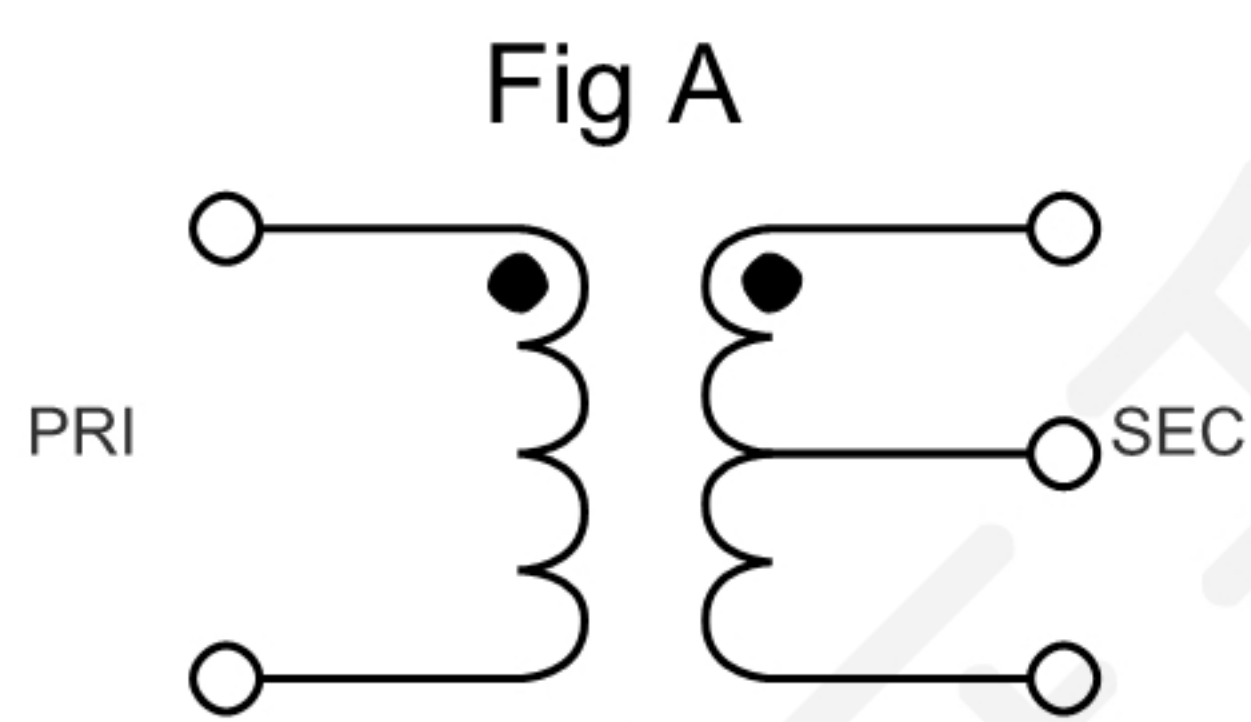

Recommended layout(mm)

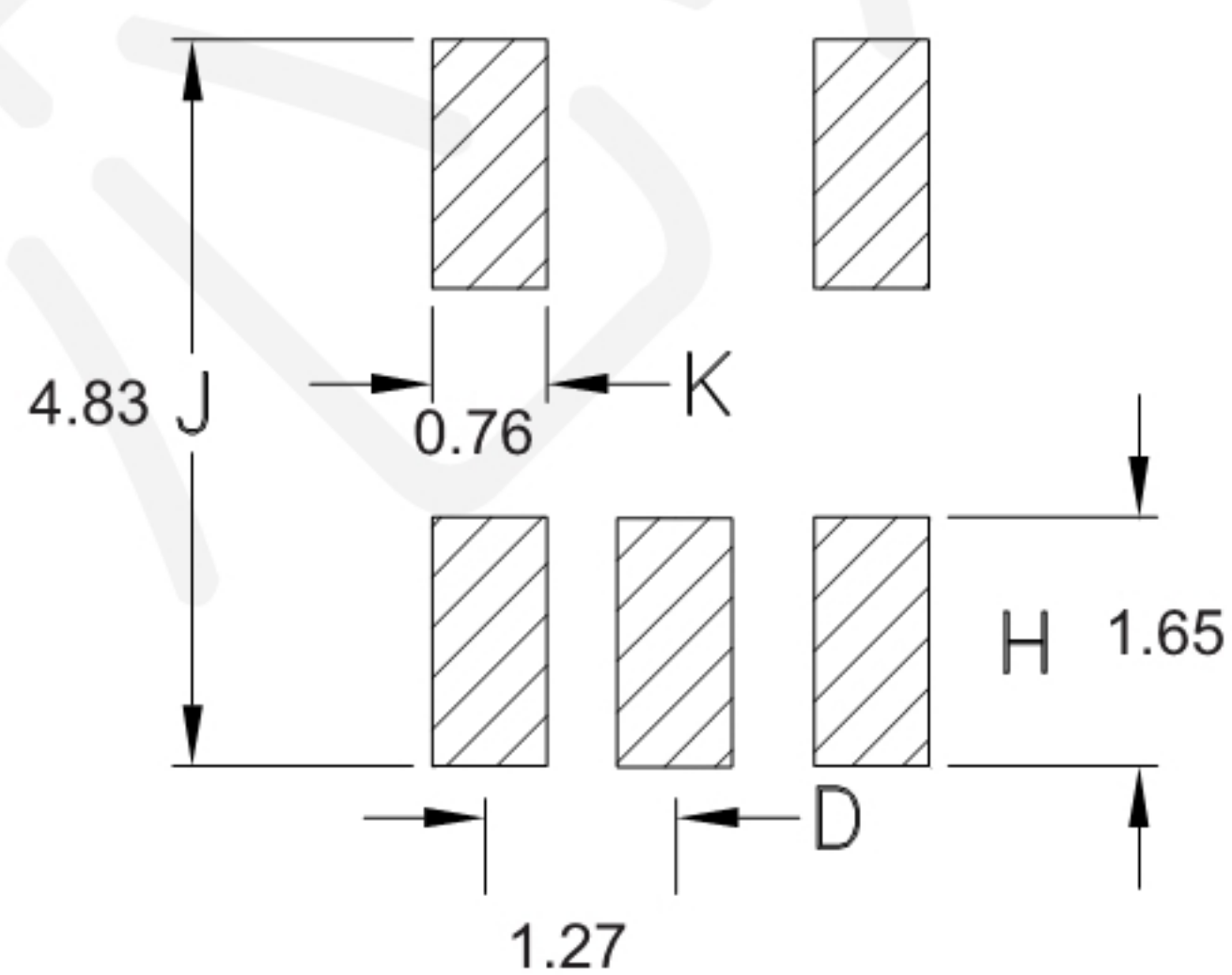

Pin Connections

Input	4
Output 1	3
Output 2	1
Ground	2,6

Features

- Operating temperature range: -40°C to +125°C
- Storage temperature range: -55°C to +100°C
- 260°C Reflow Compatible
- RoHS compliant and lead free
- Input Power: 2000mW Max
- DC Current: 1500mA Max

Applications

For Docsis 3.0 & 3.1 Cable Modem.
For Wideband Push-pull Amplifiers.
For CATV Amplifiers Module & Set top box.
For CATV Optical Receivers and Amplifiers.
For VHF/UHF Transmitters and Push-pull Amplifiers.

Electrical Specifications: TA=25°C, 0dBm, Z0=75Ω

Parameter	Test Conditions	Units	Min	Typ	Max
Main line Loss (Pin4-3)	5-300MHz	dB	—	3.0	4.5
Main line Loss (Pin4-1)	5-300MHz	dB	—	3.5	5.0
Amplitude Balance	5-300MHz	dB	0.0	0.5	1.5
Phase Balance	5-300MHz	°	0.0	5.0	15.0
Input Return Loss(Pin4)	5-300MHz	dB	5.0	8.0	—

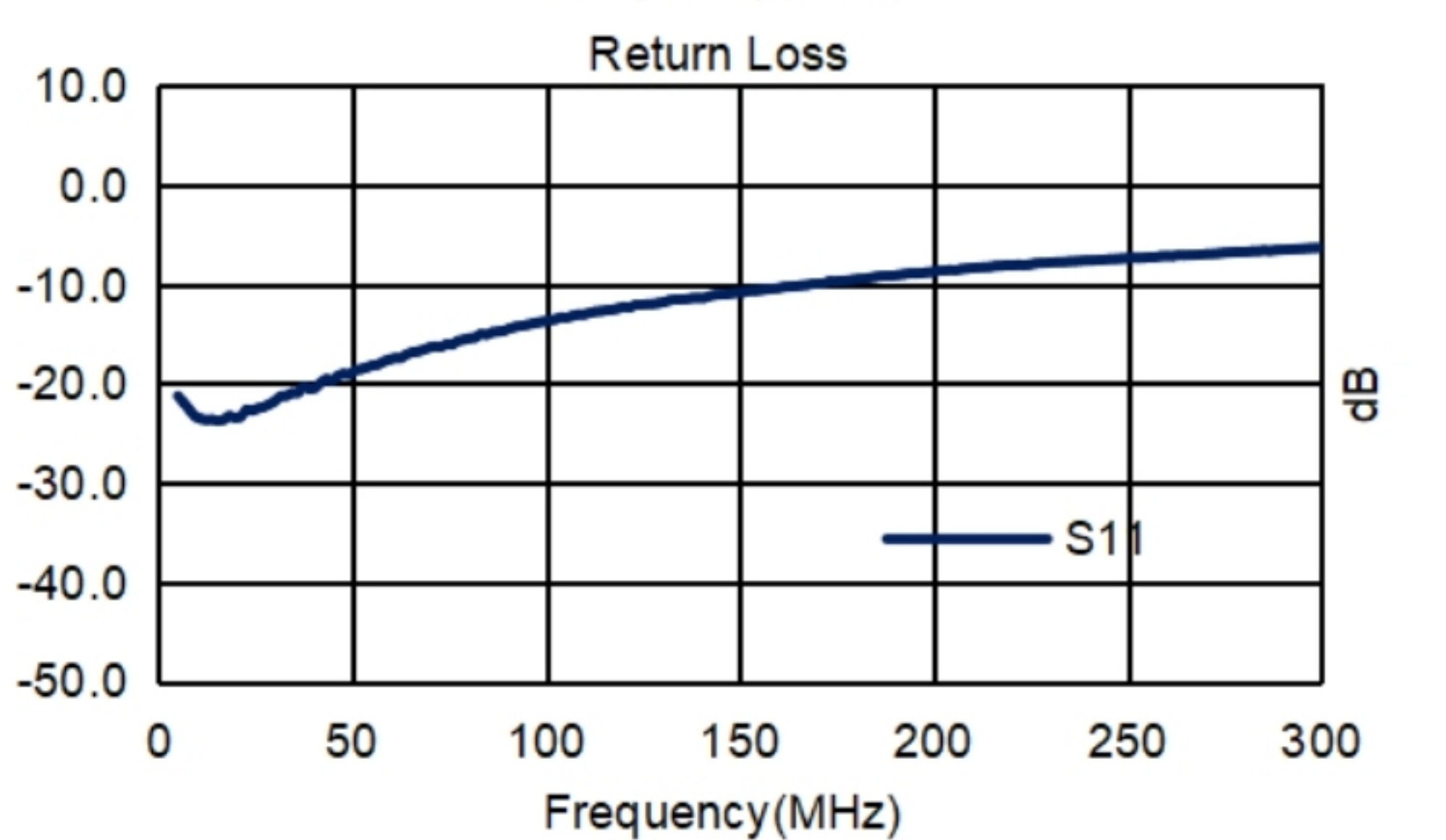
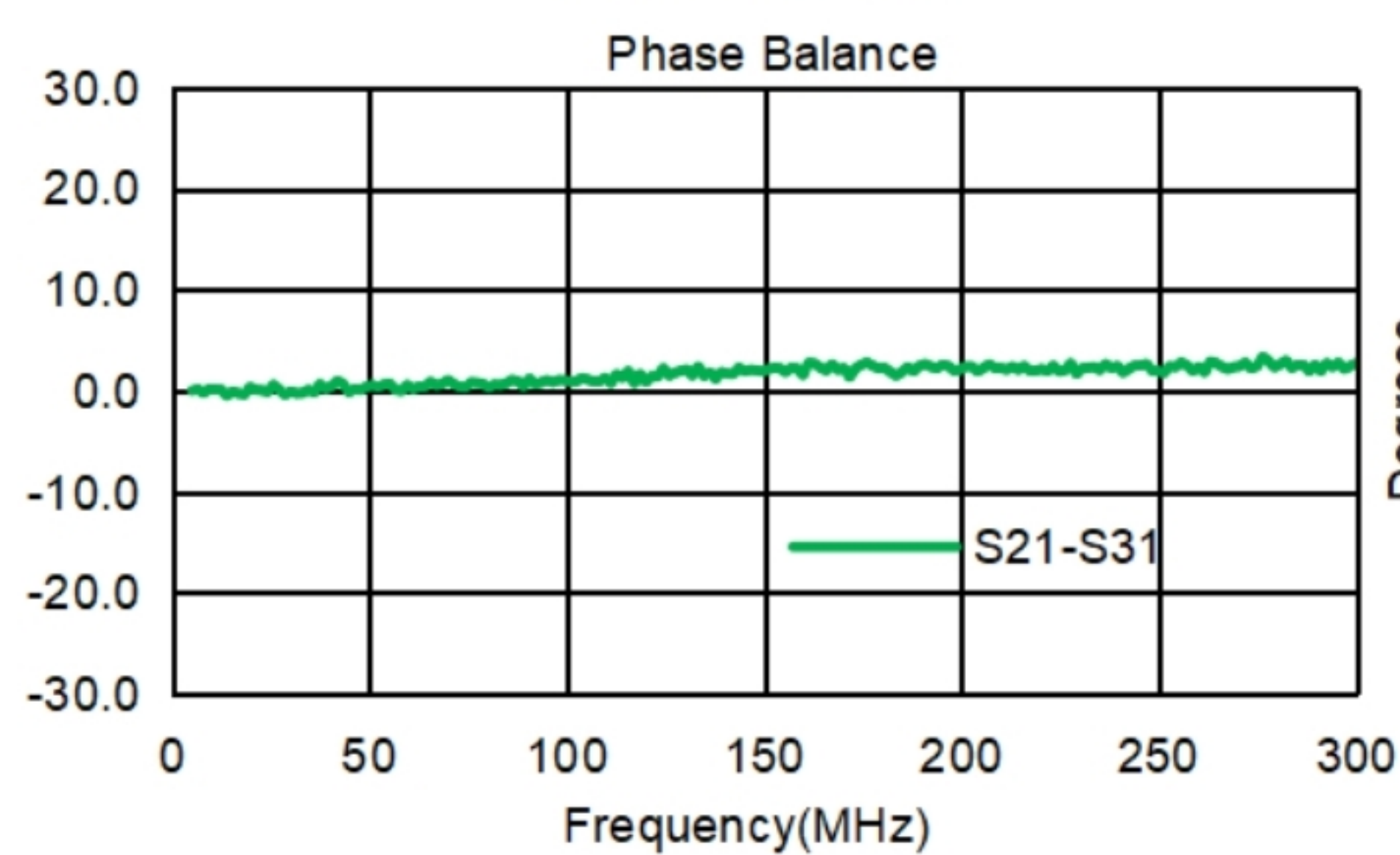
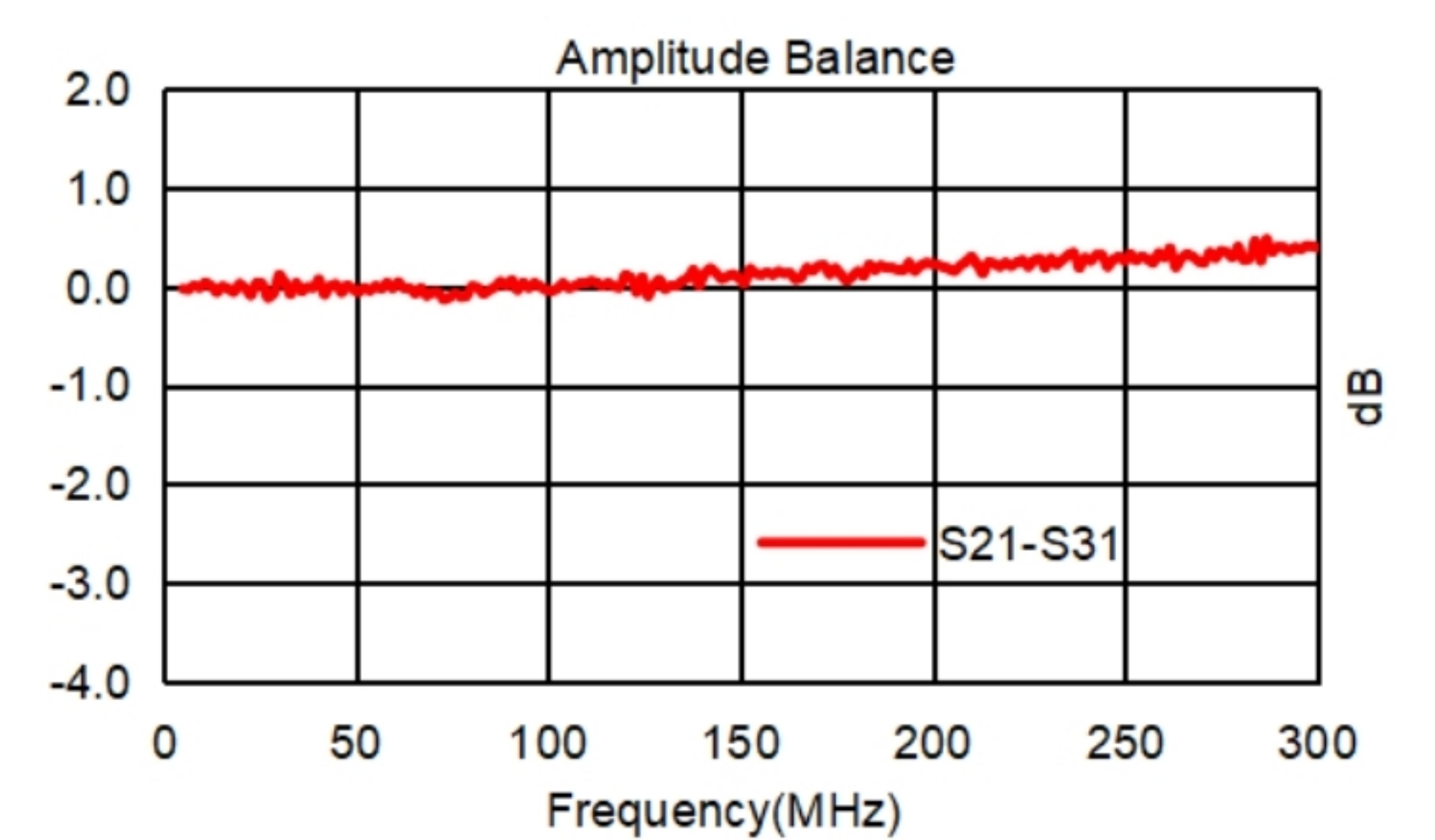
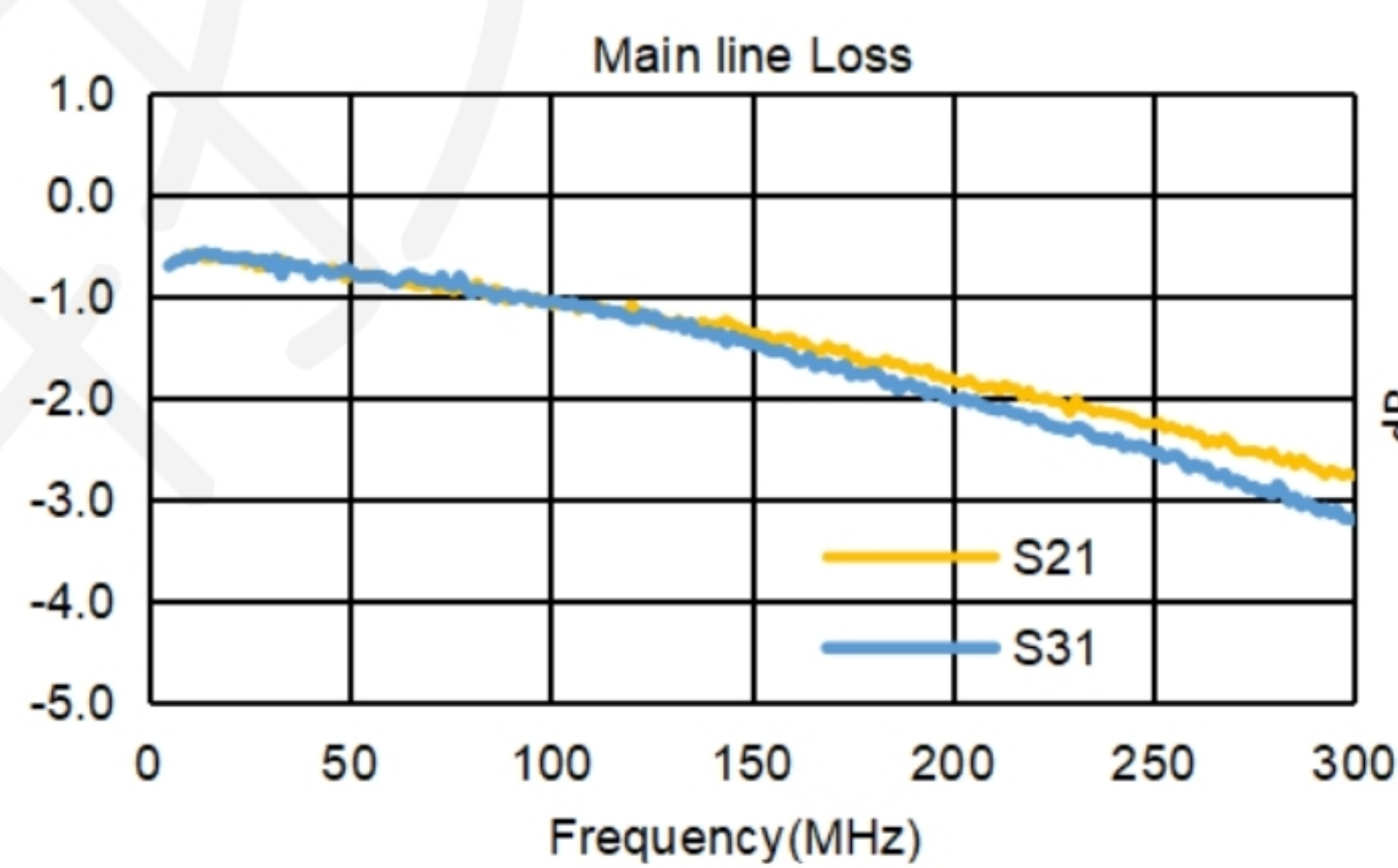

Carrier Tape Orientation

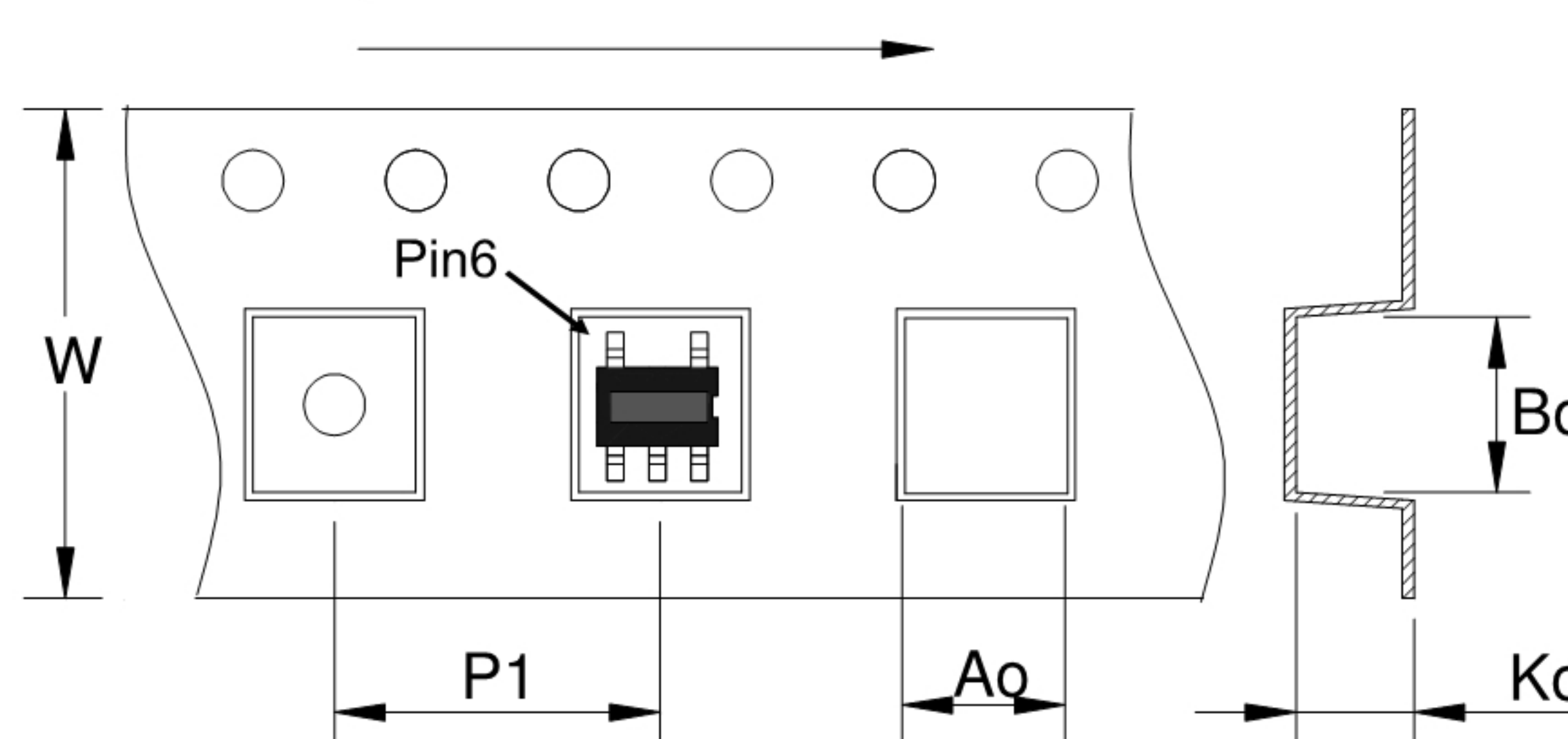

Tape & Reel Information

Parameter	Units	Value
Qty per reel	PCS	2000
Reel Size	mm	330
Tape Width	mm	12.00
Pitch	mm	8.00
Ao	mm	4.50
Bo	mm	4.50
Ko	mm	3.50