

Features:

- ◆ 1.5: 1 Impedance
- ◆ 50Ω Impedance
- ◆ Frequency: 0.5 to 2200 MHz
- ◆ 260°C Reflow Compatible
- ◆ RoHS* compliant
- ◆ Operating temperature range: -40°C to +85°C
- ◆ Storage temperature range: -55°C to +100°C



Applications:

- ◆ For broadband and wireless communications
- ◆ For VHF/UHF receivers/transmitters and push-pull amplifiers

Dimension Diagram (Unit:mm) :

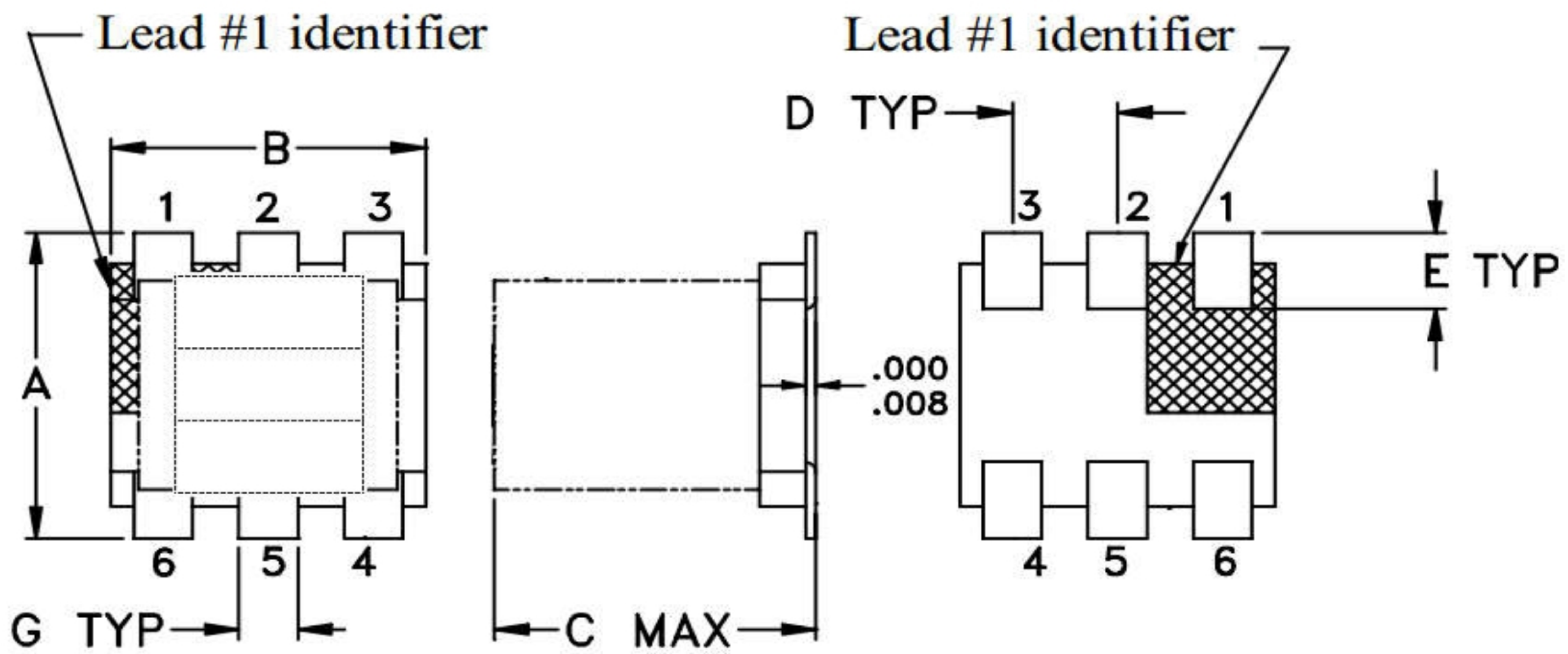

A=4.20±0.20 B=3.80±0.20 C=2.80±0.20 D=1.27±0.05 E=0.70±0.05

Electrical structure:

Recommended layout:

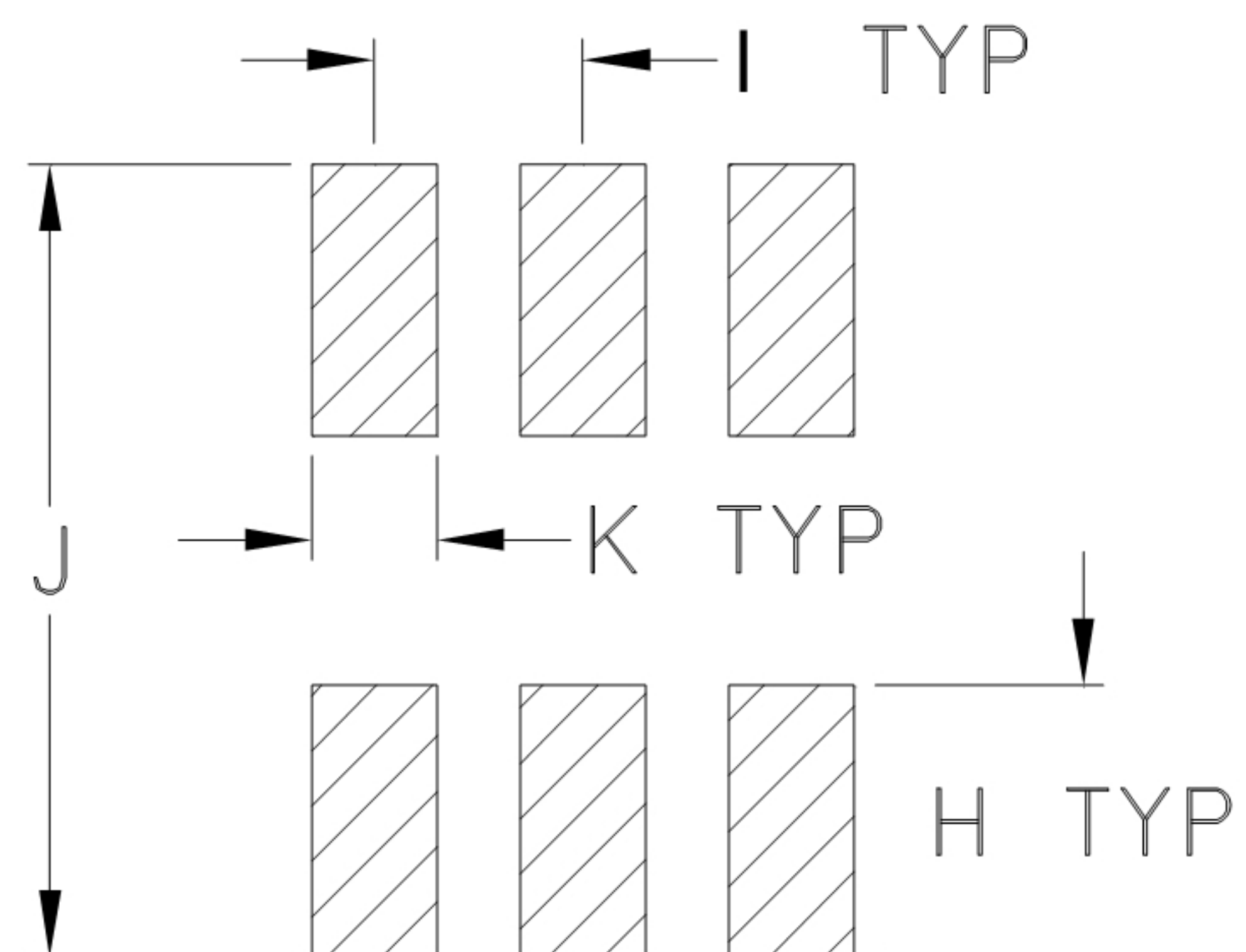
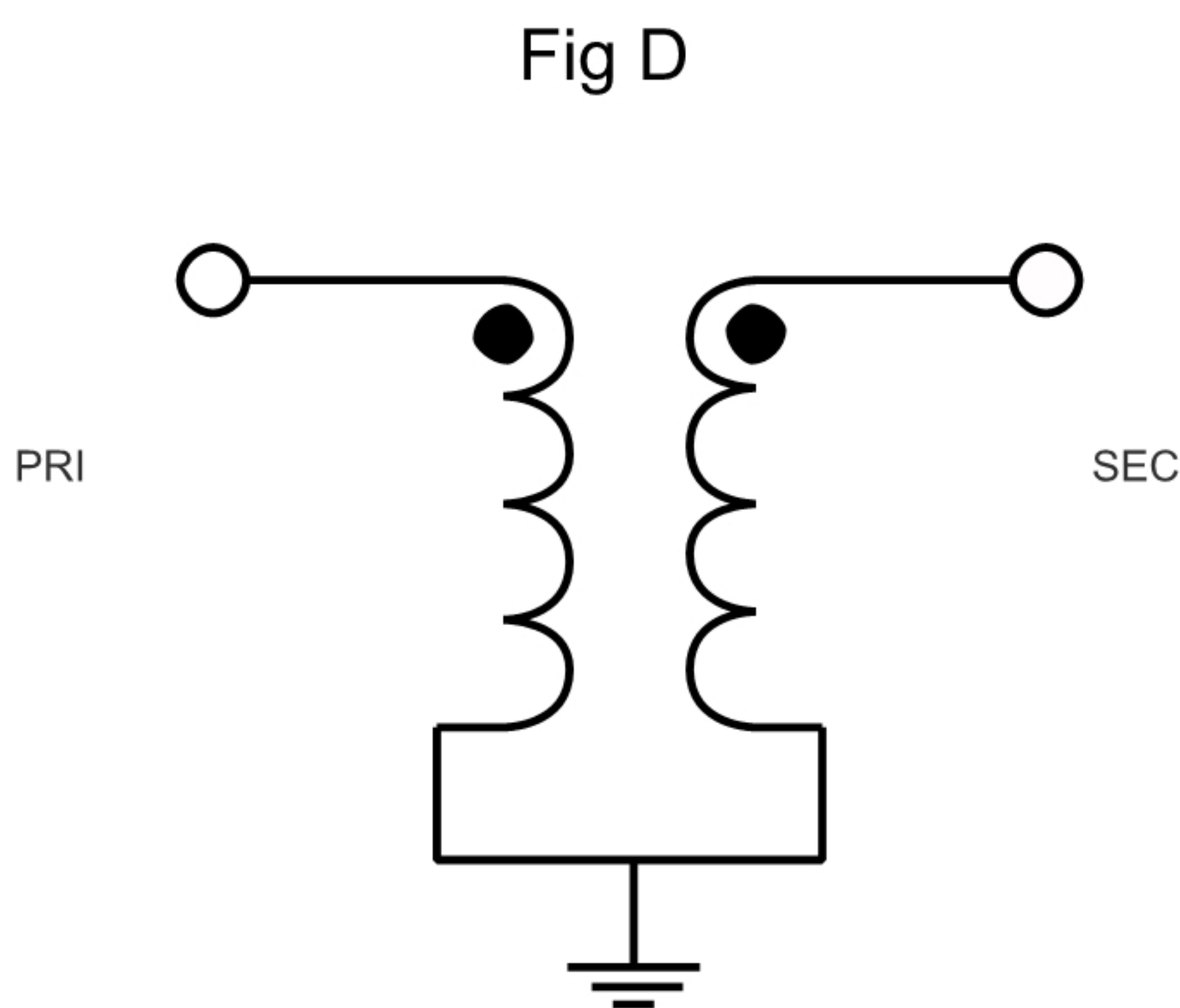

H=1.65 I=1.27 J=4.80 K=0.76

Pin Configuration:

Pin No.	Function
1	Primary Dot(e.g. 75 Ohm)
2,3,5	Not Connected
4	Ground
6	Secondary Dot(e.g. 50 Ohm)

Electrical Specifications: TA=25°C, 0dBm, Z0=50Ω:

Parameter	Test Conditions	Units	Min	Typ	Max
Main line Loss	0.5-1100MHz	dB	—	0.5	1.2
Main line Loss	1100-2200MHz	dB	—	1.2	2.5
Input Return Loss	0.5-2200MHz	dB	8.0	15.0	—

Main line Loss

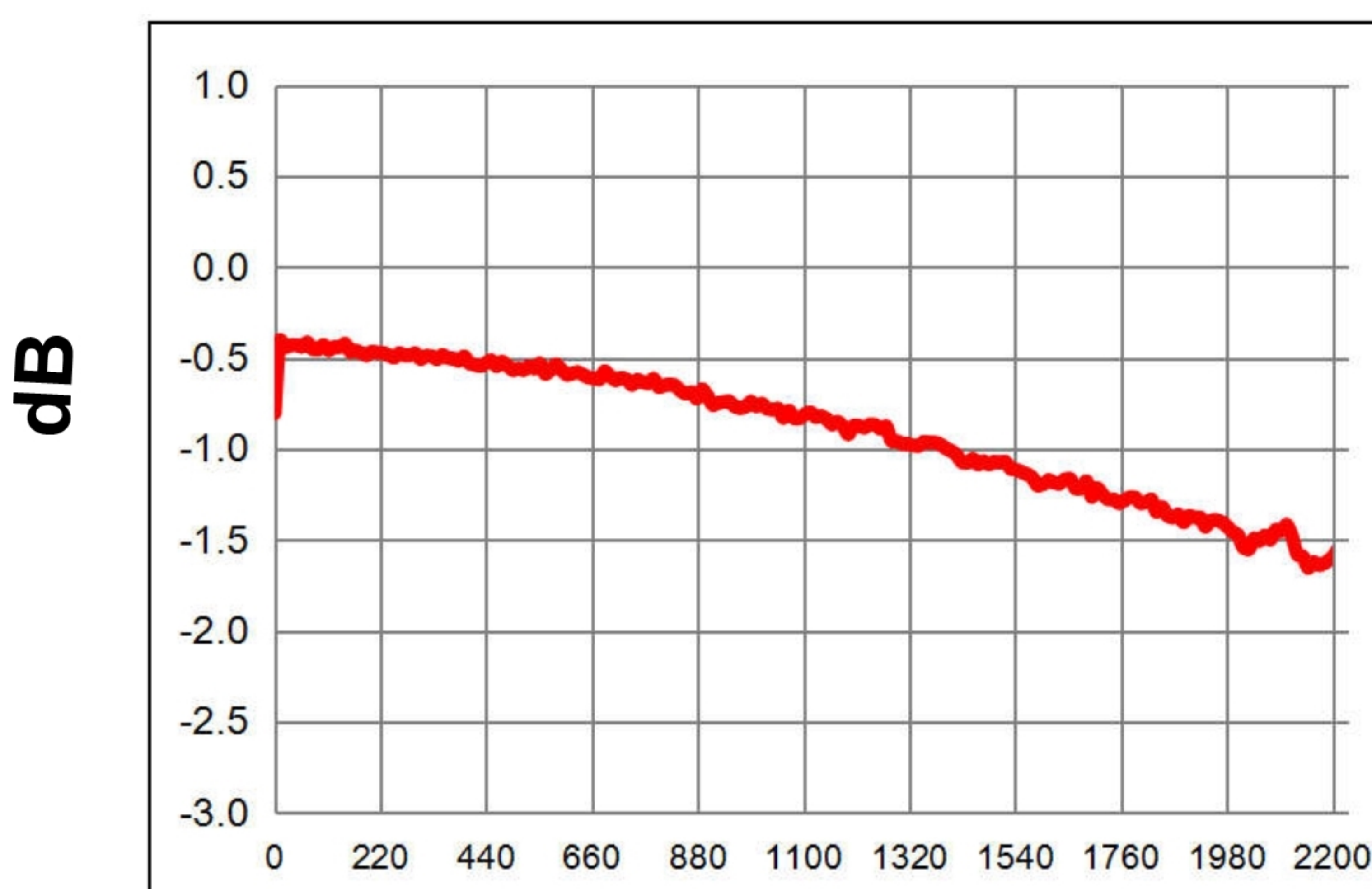

Frequency(MHz)

Input Return Loss

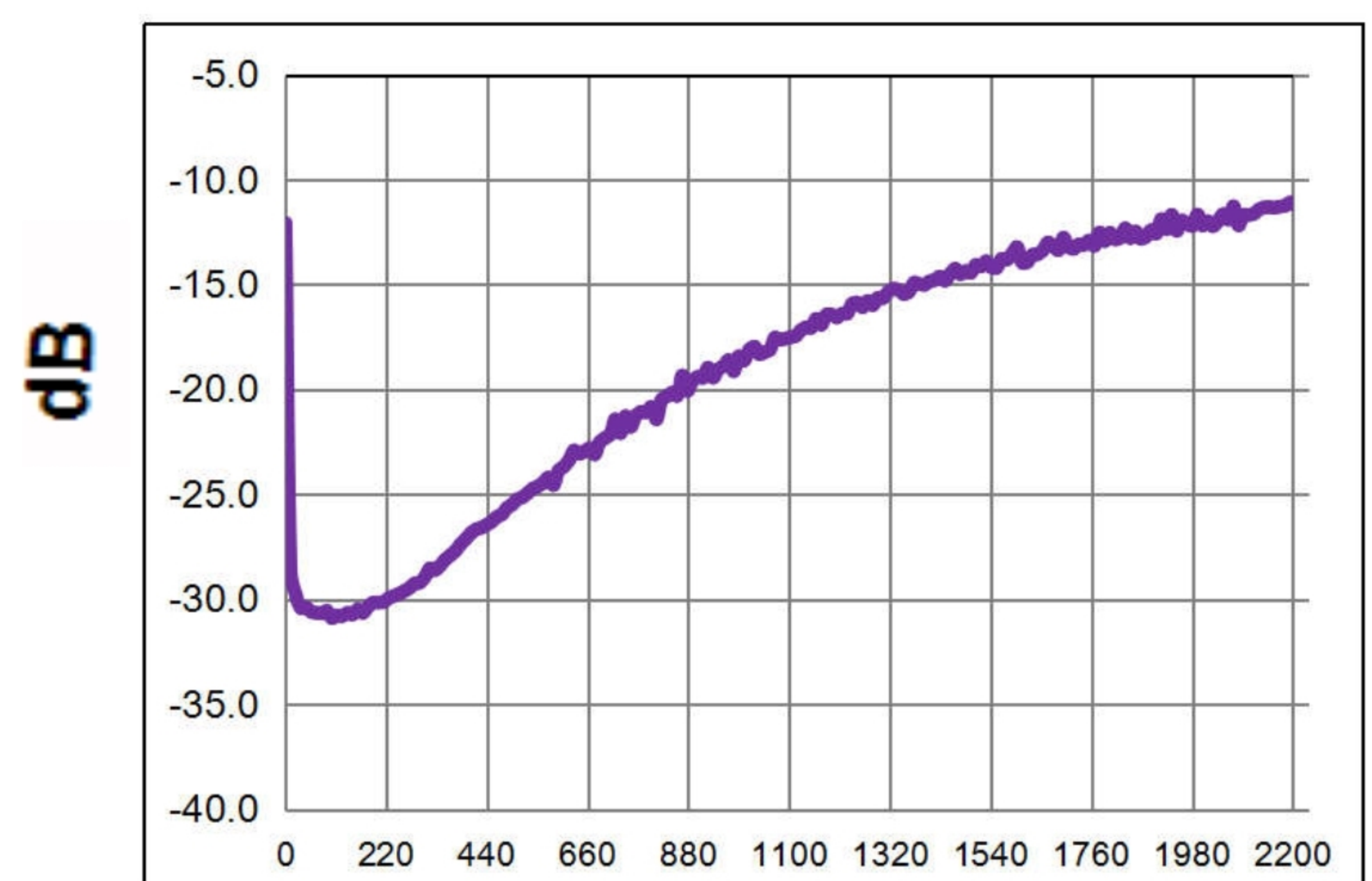

Frequency(MHz)

Recommended Soldering Temperature Graph:

Typical RoHS Reflow Profile

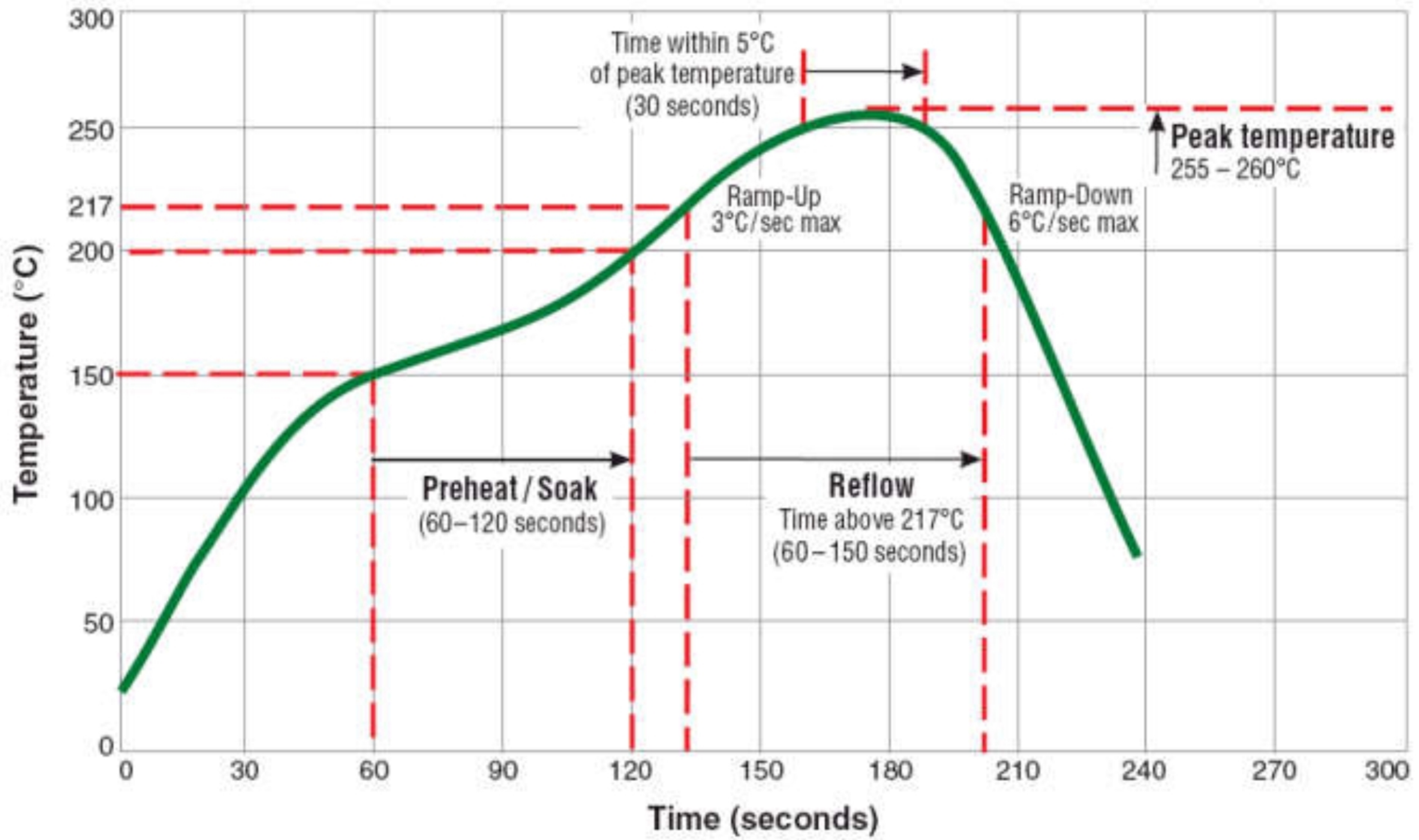

Packing Dimension For Caeier Tape(UNIT:mm):

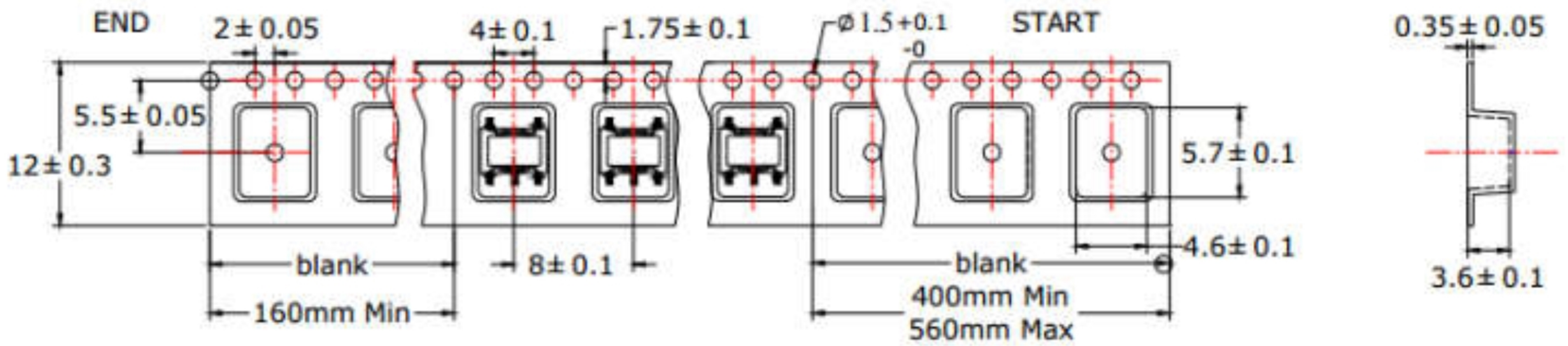

QUANTITY
2000pcs/reel
4Reel/Middle Carton
4Middle Carton/Big Carton
32000pcs/Big Carton

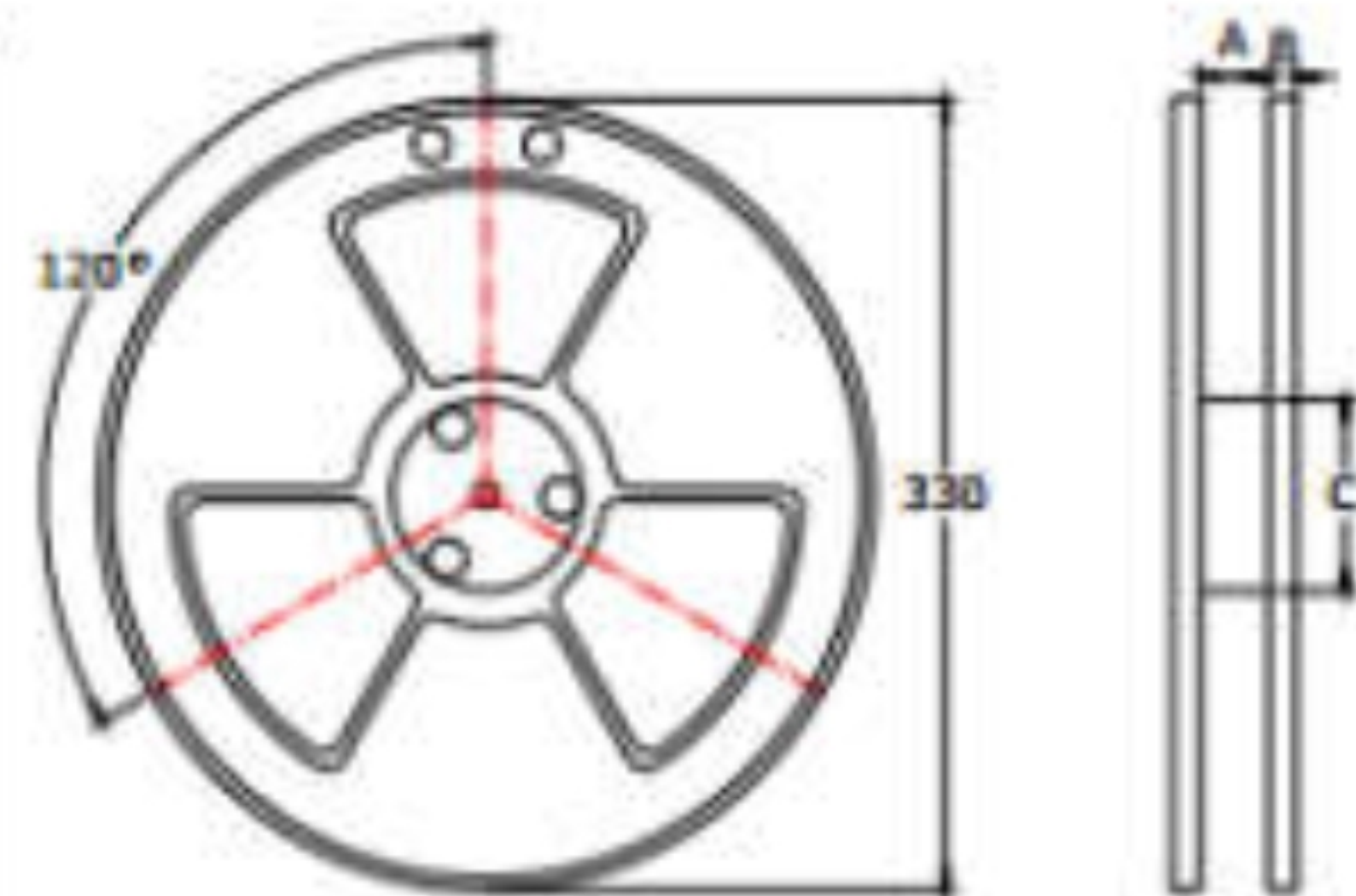

SPEC	8	12	16	24
DIM A±0.1	8.5	12.5	16.5	24.5
DIM B±0.1	2.3	2.3	2.3	2.3
DIM C±0.1	100	100	100	100

